

IEEE Guide for the Application of Insulation Coordination

Sponsor

**Technical Council
of the
IEEE Power Engineering Society**

Approved 26 June 1999

IEEE-SA Standards Board

Abstract: The calculation method for selection of phase-to-ground and phase-to-phase insulation withstand voltages for equipment is presented. This guide gives methods for insulation coordination of different air-insulated systems like transmission lines and substations. The methods of analysis are illustrated by practical examples.

Keywords: atmospheric correction factor, backflash, basic lightning impulse level (BIL), basic switching impulse insulation level (BSL), clearances, crest value, ground fault factor, insulation coordination, insulation design, overvoltage, phase-to-ground insulation configuration, phase-to-phase insulation configuration, protective margin, protective radio, shielding failures, standard withstand voltages, voltage stress

The Institute of Electrical and Electronics Engineers, Inc.
3 Park Avenue, New York, NY 10016-5997, USA

Copyright © 1999 by the Institute of Electrical and Electronics Engineers, Inc.
All rights reserved. Published 27 October 1999. Printed in the United States of America.

Print: ISBN 0-7381-1761-7 SH94764
PDF: ISBN 0-7381-1762-5 SS94764

No part of this publication may be reproduced in any form, in an electronic retrieval system or otherwise, without the prior written permission of the publisher.

IEEE Standards documents are developed within the IEEE Societies and the Standards Coordinating Committees of the IEEE Standards Association (IEEE-SA) Standards Board. Members of the committees serve voluntarily and without compensation. They are not necessarily members of the Institute. The standards developed within IEEE represent a consensus of the broad expertise on the subject within the Institute as well as those activities outside of IEEE that have expressed an interest in participating in the development of the standard.

Use of an IEEE Standard is wholly voluntary. The existence of an IEEE Standard does not imply that there are no other ways to produce, test, measure, purchase, market, or provide other goods and services related to the scope of the IEEE Standard. Furthermore, the viewpoint expressed at the time a standard is approved and issued is subject to change brought about through developments in the state of the art and comments received from users of the standard. Every IEEE Standard is subjected to review at least every five years for revision or reaffirmation. When a document is more than five years old and has not been reaffirmed, it is reasonable to conclude that its contents, although still of some value, do not wholly reflect the present state of the art. Users are cautioned to check to determine that they have the latest edition of any IEEE Standard.

Comments for revision of IEEE Standards are welcome from any interested party, regardless of membership affiliation with IEEE. Suggestions for changes in documents should be in the form of a proposed change of text, together with appropriate supporting comments.

Interpretations: Occasionally questions may arise regarding the meaning of portions of standards as they relate to specific applications. When the need for interpretations is brought to the attention of IEEE, the Institute will initiate action to prepare appropriate responses. Since IEEE Standards represent a consensus of all concerned interests, it is important to ensure that any interpretation has also received the concurrence of a balance of interests. For this reason, IEEE and the members of its societies and Standards Coordinating Committees are not able to provide an instant response to interpretation requests except in those cases where the matter has previously received formal consideration.

Comments on standards and requests for interpretations should be addressed to:

Secretary, IEEE-SA Standards Board
445 Hoes Lane
P.O. Box 1331
Piscataway, NJ 08855-1331
USA

<p>Note: Attention is called to the possibility that implementation of this standard may require use of subject matter covered by patent rights. By publication of this standard, no position is taken with respect to the existence or validity of any patent rights in connection therewith. The IEEE shall not be responsible for identifying patents for which a license may be required by an IEEE standard or for conducting inquiries into the legal validity or scope of those patents that are brought to its attention.</p>

Authorization to photocopy portions of any individual standard for internal or personal use is granted by the Institute of Electrical and Electronics Engineers, Inc., provided that the appropriate fee is paid to Copyright Clearance Center. To arrange for payment of licensing fee, please contact Copyright Clearance Center, Customer Service, 222 Rosewood Drive, Danvers, MA 01923 USA; (978) 750-8400. Permission to photocopy portions of any individual standard for educational classroom use can also be obtained through the Copyright Clearance Center.

Introduction

(This introduction is not a part of IEEE Std 1313.2-1999, IEEE Guide for the Application of Insulation Coordination.)

This guide is the second part of a major revision of ANSI C92.1-1982. The guide is divided into two parts: IEEE Std 1313.1-1996 (Part 1) presents the definitions and the procedure for insulation coordination. IEEE Std 1313.2-1999 (Part 2) is an application guide, which presents practical examples. The technical content of Part 2, particularly 6.2 and 6.3, is taken with permission from the book *Insulation Coordination for Power System* by Andrew R. Hileman, published by Marcel Dekker Inc., New York, NY.

New additions to this guide include the concepts of phase-phase insulation coordination and longitudinal insulation coordination, which considers switching surges and the power frequency voltage across an open switch. The introduction of the very fast front short-duration overvoltages is an acknowledgment of the problems observed when a disconnect switch operates in a gas insulated substation (GIS).

The basic concept of insulation coordination remains the same as in ANSI C92.1-1982. The first step is the determination of voltage stresses using digital computer simulation, transient analyzer, or mathematical methods such as those presented in this guide. These analyses result in nonstandard overvoltage waveforms, which are converted to equivalent standard wave shapes. The second step is the selection of insulation strength to achieve the desired level of probability of failure. The standard describes the determination of both the conventional and statistical BIL and BSL.

This standard is prepared by the Insulation Coordination Working Group, under the sponsorship of the Technical Council of the IEEE Power Engineering Society. At the time this application guide was completed, the Insulation Coordination Working Group had the following membership:

George G. Karady, Chair

Richard G. Cottrell
John C. Crouse
Richard Crowdis

Andrew Robert Hileman
Donald E. Hutchinson
Stephen R. Lambert
Gerald E. Lee

Mark F. McGranaghan
Joe R. Ribeiro
Edward J. Yasuda

The following members of the balloting committee voted on this guide:

Raymond L. Capra
Richard G. Cottrell
John C. Crouse
Richard Crowdis
Robert W. Dempsey
W. Bruce Dietzman
James S. Edmonds
Gary R. Engmann
Brian E. B. Gott

Bal K. Gupta
James H. Harlow
Andrew Robert Hileman
Donald E. Hutchinson
J. Harry Jones
George G. Karady
James L. Kirtley
Stephen R. Lambert
Gerald E. Lee

John W. Matthews
Mark McGranaghan
Stig L. Nilsson
William R. Prince
Joe R. Ribeiro
Ken H. Sebra
Eddy So
Howard L. Willis
Edward J. Yasuda

When the IEEE-SA Standards Board approved this standard on 26 June 1999, it had the following membership:

Richard J. Holleman, *Chair*

Donald N. Heirman, *Vice Chair*

Judith Gorman, *Secretary*

Satish K. Aggarwal
Dennis Bodson
Mark D. Bowman
James T. Carlo
Gary R. Engmann
Harold E. Epstein
Jay Forster*
Ruben D. Garzon

James H. Gurney
Lowell G. Johnson
Robert J. Kennelly
E. G. "Al" Kiener
Joseph L. Koepfinger*
L. Bruce McClung
Daleep C. Mohla
Robert F. Munzner

Louis-François Pau
Ronald C. Petersen
Gerald H. Peterson
John B. Posey
Gary S. Robinson
Akio Tojo
Hans E. Weinrich
Donald W. Zipse

*Member Emeritus

Also included is the following nonvoting IEEE-SA Standards Board liaison:

Robert E. Hebner

Kim Breitfelder
IEEE Standards Project Editor

Contents

1.	Overview.....	1
1.1	Scope.....	1
1.2	Purpose.....	1
2.	References.....	1
3.	Voltage stresses.....	3
3.1	Origin and classification of voltage stresses.....	3
3.2	Characteristics of overvoltage protective devices.....	9
4.	Insulation strength.....	11
4.1	General.....	11
4.2	Insulation behavior at power frequency voltages.....	12
4.3	Influences of atmospheric conditions on external insulation.....	12
4.4	Probability of disruptive discharge.....	13
4.5	Influence of polarity and overvoltage shape.....	13
4.6	Phase-phase and longitudinal insulation.....	14
5.	Performance/reliability criterion.....	14
5.1	Transmission lines.....	14
5.2	Substations.....	14
6.	Insulation coordination design.....	15
6.1	Design procedures for continuous power frequency voltage and temporary overvoltages.....	15
6.2	Procedures for switching overvoltages (SOV).....	20
6.3	Procedures for lightning overvoltages.....	31
7.	Final selection.....	58
7.1	Transmission lines.....	58
7.2	Substations.....	58
	Annex A (informative) Bibliography.....	60

IEEE Guide for the Application of Insulation Coordination

1. Overview

1.1 Scope

The insulation coordination standard and guide apply to three-phase ac systems above 1 kV and are divided into two parts.

IEEE Std 1313.1-1996 (Part 1) specifies the procedure for selection of the withstand voltages [basic lightning impulse insulation level (BIL) and basic switching impulse insulation level (BSL)] for equipment phase-ground and phase-phase insulation systems. It also identifies a list of standard insulation levels. Although the principles of this standard also apply to transmission line insulation systems, the insulation levels may be different from those identified as standard insulation levels.

This guide (Part 2) is an application guide with practical examples, intended to provide guidance in the determination of the withstand voltages and to suggest calculation methods and procedures. The insulation coordination examples for selected equipment are designed to explain the principles of Part 1. The guide is intended for air-insulated ac systems; caution should be exercised in the case of gas-insulated systems (GIS).

1.2 Purpose

It should be recognized that absolute protection of station equipment is theoretically impossible. Even if arresters are located at the terminals of all apparatuses, equipment failures can occur. The probabilistic method, that is, designing for a mean time between failures (MTBF) criterion, is proposed here not only to permit a realistic basis of design, but perhaps more importantly, to form a consistent measure of design based on reliability.

2. References

This guide shall be used in conjunction with the following publications. When the following standards are superseded by an approved revision, the revision shall apply.

ANSI C84.1-1995, Electric Power System and Equipment—Voltage Ratings (60 Hz).¹

ANSI C92.2-1987, American National Standard for Power Systems—Alternating-Current Electrical Systems and Equipment Operating at Voltages Above 230 kV Nominal Preferred Voltage Ratings.

¹ANSI publications are available from the Sales Department, American National Standards Institute, 11 West 42nd Street, 13th Floor, New York, NY 10036, USA (<http://www.ansi.org/>).

IEEE Std 4-1995, IEEE Standard Techniques for High Voltage Testing.²

IEEE Std 24-1984, IEEE Standard Performance Characteristics and Dimensions for Outdoor Apparatus Bushings.

IEEE Std 100-1996, IEEE Standard Dictionary of Electrical and Electronics Terms, Sixth Edition.

IEEE Std 516-1995, IEEE Guide for Maintenance Methods on Energized Power Lines.

IEEE Std 987-1985, IEEE Guide for Application of Composite Insulators (withdrawn).³

IEEE Std 998-1996, IEEE Guide for Direct Lightning Stroke Shielding of Substations.

IEEE Std 1313.1-1996, IEEE Standard for Insulation Coordination—Definitions, Principles, and Rules.

IEEE Std C2-1997, National Electric Safety Code[®] (NESC[®]).

IEEE Std C37.04-1999, IEEE Standard Rating Structure for AC High-Voltage Circuit Breakers Rated on a Symmetrical Current Basis.

IEEE Std C37.48-1988 (Reaff 1992), IEEE Guide for Application, Operation, and Maintenance of High-Voltage Fuses, Distribution Enclosed Single-Pole Air Switches, Fuse Disconnecting Switches, and Accessories.

IEEE Std C57.12.00-1993, IEEE Standard General Requirements for Liquid-Immersed Distribution, Power and Regulating Transformers.

IEEE Std C57.12.01-1989, IEEE Standard General Requirements for Dry-Type Distribution and Power Transformers Including Those with Solid Cast and/or Resin-Encapsulated Windings (withdrawn).⁴

IEEE Std C57.13-1993, IEEE Standard Requirements for Instrument Transformers.

IEEE Std C57.21-1990 (Reaff 1995), IEEE Standard Requirements, Terminology, and Test Code for Shunt Reactors Rated Over 500 kVA.

IEEE Std C62.1-1989 (Reaff 1994), IEEE Standard for Gapped Silicon-Carbide Surge Arresters for AC Power Circuits.

IEEE Std C62.11-1999, IEEE Standard for Metal-Oxide Surge Arresters for Alternating Current Power Circuits.

IEEE Std C62.2-1987 (Reaff 1994), IEEE Guide for the Application of Gapped Silicon-Carbide Surge Arresters for Alternating-Current Systems.

IEEE Std C62.22-1997 (Reaff 1993), IEEE Guide for the Application of Metal-Oxide Surge Arresters for Alternating-Current Systems.

IEEE Std C62.92.1-1987 (Reaff 1993), IEEE Guide for the Application of Neutral Grounding in Electrical Utility Systems, Part I—Introduction.

²IEEE publications are available from the Institute of Electrical and Electronics Engineers, 445 Hoes Lane, P.O. Box 1331, Piscataway, NJ 08855-1331, USA (<http://www.standards.ieee.org/>).

³IEEE Std 987-1985 has been withdrawn; however, copies can be obtained from Global Engineering, 15 Inverness Way East, Englewood, CO 80112-5704, USA, tel. (303) 792-2181 (<http://global.ihs.com/>).

⁴IEEE Std C57.12.01-1989 has been withdrawn; however, copies can be obtained from Global Engineering, 15 Inverness Way East, Englewood, CO 80112-5704, USA, tel. (303) 792-2181 (<http://global.ihs.com/>).

3. Voltage stresses

3.1 Origin and classification of voltage stresses

IEEE Std 1313.1-1996 identifies classes and shapes of different types of overvoltages. In addition, Part 1 identifies the continuous (power frequency) voltages that are the result of normal operation of the power system. There are many possible causes for each of the different types of overvoltage. Some of the common overvoltages are

- a) Temporary overvoltages that are caused by faults, load rejection, line energizing, resonance conditions, ferroresonance, or by some combination of these factors.
- b) Switching (slow-front) overvoltages that are caused by switching operations, fault initiation, or remote lightning strokes.
- c) Lightning (fast-front) overvoltages that are caused primarily by lightning strikes but can also be caused by some switching operations or fault initiation.
- d) Very fast-front overvoltages that are the result of switching operations or faults and are usually associated with high voltage disconnect switch operation, GIS, and cable connected motors.

3.1.1 Continuous power frequency voltages

The designated maximum system voltage is identified in ANSI C84.1-1995 and ANSI C92.2-1987 and is used for insulation coordination. For systems whose maximum system voltage exceeds that given in the standards, the actual maximum system operating voltage should be used.

3.1.2 Temporary overvoltages

The temporary overvoltage is described by an amplitude-duration characteristic, which is determined by system analysis.

3.1.2.1 Fault overvoltages

Faults produce temporary, power frequency, phase-ground overvoltages on the unfaulted phases. Temporary overvoltages between phases or across longitudinal insulation normally do not occur. The magnitude of the overvoltage depends on the system grounding and on the fault location. Depending on the system configuration, during fault clearing, separated portions of the system may become ungrounded. A ground fault in the separated part of the system produces high overvoltages, which can be controlled by fast grounding of the neutral points or by the proper application of surge arresters that short circuit the neutral when the fault occurs.

In effectively grounded systems, the temporary overvoltage is about 1.3 pu and the duration of the overvoltage, considering backup clearing, is generally less than 1 s. In resonant grounded systems the temporary overvoltage is about 1.73 pu or greater and, with fault clearing, the duration is generally less than 10 s. In systems without fault clearing, this duration is undefined. The overvoltages are expressed in pu with reference to $\sqrt{2}V_m/\sqrt{3}$ where V_m is the maximum system voltage.

3.1.2.2 Load rejection overvoltages

Temporary overvoltages caused by load rejection are a function of the load rejected, the system topology after disconnection, and the characteristics of the sources, i.e., short-circuit power at the station, speed and voltage regulation of the generators, etc. These overvoltages are especially important in the case of load rejection at the remote end of a long line due to the Ferranti effect. Primarily, it affects the apparatus at the station connected on the line side of the remote circuit breaker.

A distinction should be made between various system configurations when large loads are rejected. A system with relatively short lines and high short circuit power at terminal stations will have low overvoltages. A system with long lines and low short circuit power at generating sites will have high overvoltages.

In a symmetrical three-phase power system the same relative overvoltages occur phase-ground and phase-phase. The longitudinal temporary overvoltages depend on whether phase opposition is possible. Phase opposition can occur when the voltages on each side of the open switching device are not synchronized.

A description of the degree and duration of phase-ground and longitudinal overvoltages for two types of substations follows:

- *System substation:* In a moderately extended system, for a full load rejection, the temporary overvoltage is usually less than 1.2 pu. The duration depends on the voltage control operation and may be up to several minutes. In extended systems, the overvoltages may reach 1.5 pu or even more when Ferranti effects or resonance occur. The duration may be in the order of seconds. The longitudinal overvoltage across a switching device is usually equal to the phase-ground overvoltage unless motors or generators, connected to the rejected side, produce phase opposition.
- *Generator station:* For a full load rejection, the overvoltage at the substation may reach up to 1.5 pu. The duration may be up to 3 s depending on the generator characteristics and control. The longitudinal temporary overvoltage is the difference between the phase-ground operating voltage at one terminal and the phase-ground temporary overvoltage on the other terminal. In the case of phase opposition the longitudinal overvoltages could be as high as 2.5 pu.

Shunt reactors, static VAR compensators, or special (grouped) arresters can control these overvoltages.

3.1.2.3 Resonance and ferroresonance overvoltages

Temporary overvoltages in this category arise from the interaction of capacitive elements (lines, cables, series capacitors) and inductive elements having nonlinear magnetizing characteristics (transformers, shunt reactors). The resonant overvoltage is initiated by a sudden change in the system configuration, such as a load rejection, single phase switching of a transformer terminated line, or isolation of a bus potential transformer (PT) through breaker capacitance. Resonant and ferroresonant overvoltages can have magnitudes greater than 3.0 pu and last until the condition is cleared. They should be limited by detuning the system from the resonant frequency, by changing the system configuration, or by damping resistors.

3.1.2.4 Transformer energization caused overvoltages

The energization of a transformer causes in-rush-current and overvoltages at the transformer terminal. These overvoltages may last for seconds and have magnitudes in the range of 1.5–2.0 pu.

3.1.2.5 Limitation of temporary overvoltages by surge arresters

Arresters are not normally sized to control temporary overvoltages except in special cases. However, surge arresters may be applied to limit or even prevent resonant overvoltages. In this case, the thermal stress on the arresters should be investigated to determine if arresters in parallel or special switched arresters are required.

3.1.3 Switching overvoltages

Switching overvoltages may have times-to-crest from 20–5000 μ s and time to half value of less than 20 000 μ s. They are generally a result of the following:

- Line energization,
- Faults and fault clearing,
- Load rejections, or
- Switching of capacitive or inductive currents.

In general, the time to crest (wavefront) is of more importance since the critical flashover voltage (CFO) is a function of the wavefront. The minimum CFO occurs at the critical wavefront (CWF), which in μs is equal to about 50 times the strike distance in meters (m). For a wavefront smaller or greater than the CWF, the CFO increases. The CFO increases by about 10% when the wavefront is in the order of 1000 μs to 2000 μs , which usually occurs when employing low-side transformer switching.

The distribution of switching overvoltages is obtained using a transient program where the breakers are randomly closed or reclosed 200 to 400 times. These overvoltages are then statistically analyzed to obtain a probability distribution, which approximates the data. Several distribution functions have been used, e.g., Gaussian, extreme-value Weibull. However, a Gaussian or normal distribution is used most frequently. This distribution is defined by its 2% value, called the statistical switching overvoltage (E_2), and by its standard deviation σ in pu of E_2 . The standard deviation pu is: σ/E_2 . To clarify the definition, E_2 means that 2% of the switching overvoltages equal or exceed E_2 . The shape of the distribution may be affected by the surge controlling action of an arrester. Typically the gapless arrester modifies the reflected wave and reduces the voltage stress caused by the return wave.

3.1.3.1 Line energization and reclosing overvoltages

In most cases a three-phase energization or reclosing of a power line produces switching overvoltages on all three phases. The overvoltage generation depends on the circuit breaker; some of the circuit breakers may not generate any overvoltages. A typical example is the circuit breaker that closes when the voltage across the contact is zero. The overvoltage calculation has to consider trapped charges left on the phases without fault in case of high-speed reclosing.

In the worst case each switching operation produces three phase-ground and three phase-phase overvoltages. Two methods are in use for characterizing the overvoltage probability distribution function; the case-peak method and the phase-peak method are described as follows:

- *Case-peak method:* From each switching operation, the highest crest overvoltage of the three overvoltages is selected and included in the probability distribution. Each switching operation contributes one value to the overvoltage distribution. This method is based on the observation that the inclusion of the other two values does not significantly affect the probability of flashover. This results in the distribution of switching surge overvoltages per three-phase energization or reclosing operation, and is used to calculate the probability of flashover per three-phase switching operation.
- *Phase-peak method:* From each switching operation, the crest switching overvoltage on each of the three-phases is included in the probability distribution. Each operation contributes three crest values to the probability distribution. This results in a per phase distribution of overvoltages that can be used to calculate a per phase probability of flashover for the switching operation.

These methods are used to determine both a phase-ground and phase-phase overvoltage distribution. Because the probability of positive and negative polarity overvoltages is equal, these methods consider only the absolute value of overvoltages, regardless of the polarity. The effect of negative and positive polarity is considered in the calculation of the switching surge flashover rate.

Line switching overvoltages may be reduced through the use of

- a) Preinsertion resistors on the circuit breakers,
- b) Controlled closing of the breaker, or
- c) Surge arresters.

A preinsertion resistor and controlled closing reduces the overvoltage along the entire line. Surge arresters only reduce the overvoltages close to the arresters.

However, within a substation, arrester separation effects may be neglected, i.e., the switching impulse voltage is approximately the same throughout the substation. Thus, an arrester provides protection to all connected equipment.

Surge arresters are usually installed phase-ground. If metal-oxide arresters are used to limit phase-ground switching overvoltages to a level lower than about 70% of E_2 (2% probability), the phase-phase overvoltage level will reach about twice the protective level of the arrester.

3.1.3.2 Typical phase-ground switching overvoltages

Table 1 presents approximate values of reclosing produced overvoltages distribution; E_2 (2% probability) and σ/E_2 at the end of the line when no arresters are present. These values were calculated by the case-peak method. In addition, approximate values of the voltage profile are presented. The voltage profile is the ratio of the switching overvoltage at the switched end to that at the open end of the line (E_2).

Table 1—Typical overvoltage from reclosing on a trapped charge

	E_2 pu	σ/E_2	Voltage profile
Preinsertion resistor is used	1.8–2.0	0.05–0.08	0.8–0.9
No preinsertion resistor is used	2.8–3.0	0.08–0.16	0.6–0.7

The maximum switching overvoltage is in the range of 1.0 to 1.5 standard deviations above E_2 .

Comparable values of E_2 for the phase-peak method are from 2% to 5% lower while the standard deviation may be 40% to 50% higher.

When arresters are present at the end of the line, the overvoltage distribution may be approximated as a combination of two Gaussian distributions, one of which is valid to the point at which the arrester significantly affects the voltage and the other, for higher voltages. The value of E_2 at the open end of the line may be approximated conservatively as the switching impulse discharge voltage of the arrester. The value of σ/E_2 for the arrester portion of the distribution is significantly decreased and is in the range of 0.01 to 0.03. Because the arrester cannot decrease the switching overvoltage along the entire line, the maximum value of E_2 is not at the open end but is within about 1/3 to 1/4 of the line length from the arrester. Therefore, it is difficult to estimate the voltage profile since the voltage initially increases along the line from the arrester location and then decreases for the remainder of the line. The maximum value of E_2 is typically less than 30% greater than the arrester protective level.

3.1.3.3 Typical phase-phase switching overvoltages

The phase-phase insulation strength of external insulation (e.g., air gaps, bushings, station and line insulators, etc.) is a function of the voltages and their polarities on each of the two phases. Therefore, the switching overvoltages distribution of both of the components and their correlation coefficient are required. Usually, the phase-phase overvoltage distribution and the positive polarity phase-ground overvoltage distribution (with the correlation coefficient) are obtained as in 3.1.3.2. From these distributions, the negative polarity distribution can be derived, or alternately, the phase-phase distribution can be used directly as illustrated in Clause 4.

Because the crest phase-phase and the positive and negative phase-ground overvoltages may not occur at the same time, the two time instants that follow are usually considered for sampling the overvoltages:

- a) The time instant of the crest of the phase-phase overvoltage: This produces the highest phase-phase overvoltages and represents the highest stress for all insulation configurations for which the dielectric strength between phases is not sensitive to the subdivision into components. A typical example is the internal insulation of a transformer or other types of internal insulation.
- b) The time instant of the crest of the positive phase-ground overvoltage: Although this time instant may produce lower phase-phase overvoltages, the insulation strength may be lower, thus producing a higher probability of flashover. Typical examples are air clearances or air-porcelain insulation.

The overvoltage values belonging to the selected time instances are used to generate overvoltage probability distributions and their correlation coefficients. This method results in three distribution curves: phase-phase, positive phase-ground, and negative phase-ground, for each of the two time instances.

In general, the comparison of these distribution curves indicates that the overvoltage distribution curves for each of the two time instances are approximately equal. Consequently, maximum phase-phase and the maximum phase-ground overvoltage distributions are commonly used.

Correlation coefficients between the phase-phase and positive phase-ground overvoltages are generally high, in the range of +0.7 to +0.9, while the coefficients between the positive and negative overvoltages are generally low and may be either positive or negative.

The value of the statistical phase-phase switching overvoltage, E_{2p} , may be estimated from the value of the statistical phase-ground switching overvoltage, E_2 . The ratio of E_{2p}/E_2 only varies between 1.6–1.5 while the value of E_2 ranges between 2.0 to 3.0. A ratio of about 1.55 appears reasonable for all values of E_2 . As an example, for an E_2 of 2.8 pu, E_{2p} is 4.35 pu. Also, in general, the values for σ/E_{2p} are equal to the values of σ/E_2 . The maximum phase-phase switching overvoltage is approximately 1.0 to 1.5 standard deviations above E_{2p} . In addition, the values of voltage profiles are similar to those for phase-ground overvoltages.

3.1.3.4 Longitudinal switching overvoltages

During energization or reclosing, the longitudinal overvoltage is the difference between the continuous operating voltage at one terminal of the switching device and the switching overvoltage at the other terminal.

In synchronized systems, the highest switching overvoltage and the operating voltage have the same polarity, and the longitudinal insulation is exposed to a lower overvoltage than the phase-ground insulation.

The longitudinal insulation between nonsynchronous systems can be subject to energization overvoltages of one polarity at one terminal and the crest of the operating voltage of the other polarity at the other terminal. Consequently in this case, the longitudinal insulation is exposed to significantly higher overvoltages than the phase-ground insulation.

3.1.3.5 Fault overvoltages

During line-to-ground fault initiation and clearing, overvoltages with wave shapes similar to those found during switching are produced. Conservative estimates for the maximum overvoltage are shown in Equation (1) and Equation (2):

$$\text{Fault initiation: maximum} = (2k - 1) \text{ pu} \quad (1)$$

$$\text{Fault clearing: maximum} = 2.0 \text{ pu} \quad (2)$$

where

k is the ground fault factor in pu of maximum line-ground system voltage

Both events cause overvoltages only between phase-ground. The overvoltages between phases can be generally neglected.

If the switching overvoltages for energizing and reclosing are controlled to below 2.0 pu, fault and fault clearing may produce higher overvoltages. These overvoltages occur at the open breaker end of a connected line.

3.1.3.6 Load rejection overvoltages

Load rejection produces a switching type overvoltage. This event may increase longitudinal voltage stresses across switching devices, the phase-ground insulator stress and the energy discharged through the arresters. If the arresters are used to limit energization and reclosing overvoltages to below 2 pu, the energy dissipation in the arresters should be studied, especially when generators, transformers, long transmission lines, or series capacitors are present.

3.1.3.7 Inductive and capacitive currents switching overvoltages

The switching of inductive or capacitive currents may produce switching overvoltages. In particular, the following switching operations should be considered:

- a) Interruption of motor starting currents
- b) Interruption of transformer or reactor magnetizing currents
- c) Switching of arc furnaces and their transformers
- d) Switching of unloaded cables and capacitor banks
- e) Interruption of currents by high-voltage fuses

Overvoltages due to restrikes or reignitions of the arc of a switching device during the interruption of capacitive currents (switching off unloaded lines, cables, or capacitor banks) can produce extremely high overvoltage. When energizing capacitor banks, in particular ungrounded banks, the phase-phase overvoltages should be evaluated.

Capacitor bank energizing produces overvoltages at the capacitor location, at line terminations, at transformers, at remote capacitor banks, and at cables. The energizing transient at the switched capacitor location should be less than 2.0 pu phase-ground and 3.0 pu phase-phase. The phase-phase transients at line terminations can be 4.0 pu or higher due to traveling wave reflections. These higher phase-phase overvoltages are most commonly associated with energizing ungrounded capacitor banks.

The chopping of inductive current produces high overvoltages due to the transformation of magnetic energy to capacitive energy.

3.1.4 Lightning overvoltages

Lightning overvoltages are caused by

- a) Strokes to the phase conductors (shielding failure)
- b) Strokes to the line shielding system which flashes over to the phase conductor (backflash)
- c) Strokes to ground in close proximity to the line, which induce overvoltages in the phase conductors (induced voltage)

Lightning overvoltages are fast front overvoltages with times to crest from 0.1–20 μ s.

For substations, shield failures, backflash, and induced overvoltages generate surge voltages that impinge on the substation equipment. Lightning induced voltages are generally below 400 kV and are important only for lower voltage systems. The incoming surges caused by the backflash are more severe than that caused by shielding failures. As these surges travel from the stroke terminating point to the station, corona decreases front steepness and the crest magnitude. The shield wire has significant impact on the wave propagation. A shield wire grounded at each tower makes the propagation velocity of the ground mode wave component very close to the conductor mode component. The magnitude of the surges caused by a backflash ranges from 70% to 120% of the positive polarity CFO of the line insulation. The front steepness is a function of the conductor size, the distance between the location of the backflash and the station.

The selected reliability criterion determines the characteristics of the incoming surge. The calculation method is described in Clause 5 and is based on the mean time between failures (MTBF).

For strokes close to the substations, lightning overvoltages between phases have approximately the same magnitude as those for phase-ground.

Backflashes usually occur on a phase with power frequency voltage that is opposite in polarity to the surge voltage. The maximum longitudinal overvoltage is the difference between the lightning overvoltage on one terminal and the power frequency voltage of opposite polarity on the other terminal of the switching device. For shielding failures, the voltage on the struck phase is random.

3.1.4.1 Lightning type overvoltages caused by switching

The connection or disconnection of nearby equipment produces surges with similar wave shapes to lightning. Generally, these short duration and fast rising surges are oscillatory. The insulation strength for this wave shape is closer to that of the standard lightning impulse than that of the standard switching impulse. Arresters cannot limit the very steep front surges. As the magnitudes usually are smaller than those caused by lightning, their importance is restricted to special cases. Maximum values of these overvoltages are approximately

- a) Switching without restriking: 2.0 pu
- b) Switching with restriking: 3.0 pu

3.1.4.2 Limitation of lightning overvoltages

Surge arresters primarily limit lightning overvoltages on substation equipment. Another method to limit lightning overvoltages that impinge on equipment is to decrease the steepness and magnitude of the incoming surge. This may be accomplished by reducing the backflash rate of the line for towers adjacent to the substation by decreasing the tower footing resistance.

In some cases, the flashover voltage of lines adjacent to the station is limited by the installation of gaps. However, a reduction in the insulation strength of the line without lowering the tower footing resistance will increase the backflash rate and result in a higher magnitude and steeper incoming surge for the same MTBF. Alternatively, the MTBF will decrease.

3.2 Characteristics of overvoltage protective devices

3.2.1 General

The following three basic types of surge arresters are used:

- a) Gapless metal-oxide surge arrester
- b) Gapped metal-oxide surge arrester
- c) Gapped silicon carbide surge arrester

Spark gaps are sometimes used to provide protection to equipment in areas of low lightning ground flash density or for protection of the open circuit breaker from lightning surges caused by subsequent strokes of lightning flash.

The voltage across the terminals of the arrester consists of a discharge voltage and a sparkover voltage if the arrester contains a gap. The discharge voltage is the voltage across the arrester when discharging a current. This voltage is defined as the crest voltage across the terminals of the arrester. The discharge voltage is a function of the magnitude and time to crest of the discharge current. For arresters employing a gap in series

with the valve block, the sparkover voltage is a function of the steepness of the front. For gapped arresters, both of these voltages must be considered.

3.2.2 Metal-oxide surge arresters

Ranges of the maximum discharge voltages are given in IEEE Std C62.22-1997. Actual values for a specific arrester may be obtained from manufacturers' literature.

3.2.2.1 Lightning overvoltages

Manufacturers provide the discharge voltage for the following conditions:

- a) For a 1.5 kA to 40 kA, 8/20 μ s discharge current: This results in a discharge voltage with a time to crest of about 7 μ s. Table 2 provides the classifying current magnitudes for various arrester classes and system voltages.
- b) For a discharge current having a front such as to produce a time to crest of the discharge voltage of 0.5 μ s: This is referred to as the 0.5 μ s discharge voltage or the front-of-wave (FOW) protective level. The classifying current magnitude is the same as the lightning impulse classifying current presented in Table 2.

Table 2—Lightning impulse classifying currents (IEEE Std 62.11-1999)

Arrester class	Max. system voltage kV	Discharge current kA
Station	800	20
	550	15
	Less than 550	10
Intermediate	Less than 161	5
Distribution Heavy duty Normal & light duty	All system voltages	10
		5

3.2.2.2 Switching overvoltages

The maximum discharge voltages are provided by the manufacturers for a discharge current having a time to crest of between 45 μ s and 60 μ s and a crest value equal to the switching impulse classifying current given in Table 3. The discharge voltage is insensitive to the variation of discharge current because of the extreme nonlinearity of the metal-oxide material. This discharge voltage is also known as the switching impulse protective level. The dependence of metal-oxide arresters' discharge voltage on the front time of the switching overvoltage is negligible.

Table 3—Switching impulse classifying currents (IEEE Std 62.11-1999)

Arrester class	Max system voltage kV	Discharge current kA
Station	3–150	500
	151–325	1000
	326–900	2000
Intermediate	3–161	500

3.2.3 Gapped metal-oxide arrester

The lightning protective level is the maximum of either the lightning impulse sparkover voltage or the discharge voltage.

3.2.4 Gapped silicon-carbide arresters

3.2.4.1 Lightning overvoltages

The manufacturers provide the discharge voltage for a 1.5–40 kA, 8/20 μ s discharge current. This results in a discharge voltage with a time to crest of about 1.2 μ s.

In addition, the manufacturer provides the gap sparkover voltages for the following conditions:

- a) For a standard lightning impulse wave shape, i.e., 1.2/50 μ s: This value is defined as the full wave sparkover voltage.
- b) For a voltage steepness of 100 kV/ μ s per 12 kV of arrester rating up to a maximum of 2000 kV/ μ s: This value is defined as the front of wave sparkover or front of wave protective level.

The maximum voltage across the arrester is the lightning impulse protective level which is either the maximum of the sparkover voltages or the discharge voltage at the lightning impulse classifying current given in Table 2.

3.2.4.2 Switching overvoltages

The arrester protective level is provided by the manufacturers and is the sum of the discharge voltage and the voltage drop across the active gap. The protection level is determined by a current impulse having a time to crest of between 45 μ s and 60 μ s and a crest value equal to the switching impulse classifying current in Table 3.

3.2.5 Spark gaps

The spark gap is a surge protective device consisting of an open air or enclosed gap that is connected phase-ground. The breakdown voltage versus time (or time lag) characteristics describes the protective capability. The gap spacing is generally selected such that the switching surges, under normal operating conditions, do not operate the gap. The selected gap spacing should consider the gap/insulation volt-time characteristics and atmospheric conditions. The gap characteristics must be obtained from the manufacturer or established by test. The gap spacing is often a compromise between the protection obtained and the number of short circuits produced by the gap operation.

4. Insulation strength

4.1 General

A number of factors influence the dielectric strength of insulation. The main factors include the following:

- a) The magnitude, shape, and polarity of the applied voltage
- b) The type of the insulation (gaseous, liquid, or a combination of these; impurities and local inhomogeneities)
- c) The physical state of the insulation medium (temperature, pressure, and other ambient conditions; mechanical stresses)
- d) Prior duty on the insulation
- e) Chemical effects
- f) Conductor surface effects, etc.

4.1.1 Self-restoring insulation

The breakdown in air is strongly dependent on the gap configuration, wave shape and polarity of the surge, and on the ambient conditions. For outdoor insulators, the effect of humidity, rain, and pollution on the surface of the insulation also become important. For metal-enclosed gas-insulated systems, the effect of the internal pressure and temperature as well as the local inhomogeneities and impurities play an important role.

4.1.2 Non-self-restoring insulation

In liquid insulation, particle impurities, bubbles caused by chemical and physical effects or by local discharges, can drastically reduce the insulation strength. An important aspect is also that the amount of chemical degradation of the insulation may tend to increase in time. The same is valid for solid insulation. However, in this case the mechanical stress may also affect the insulation strength.

4.2 Insulation behavior at power frequency voltages

In general, discharges while operating under power frequency voltage and normal operating conditions, and under temporary overvoltages, will be caused by a significant reduction in equipment insulation withstand due to severe environmental conditions or by aging of the insulation.

Rain reduces the external dielectric strength of insulators but makes no practical reductions in the strength of air gaps. The greatest reductions in dielectric strength can be expected for power frequency voltages or for switching impulses. In addition to the rate of rainfall, the insulator configuration and the conductivity of water influence the reduction of the dielectric strength.

Rain together with pollution can drastically reduce the insulation strength. Fog, dew formation, or light rain together with pollution or contamination usually causes the worst conditions.

The statistical description of the ambient conditions usually requires a large amount of data. The statistical description of aging is even more difficult. Therefore, statistical procedures are not recommended for estimation of the insulation behavior at power frequency voltages.

4.3 Influences of atmospheric conditions on external insulation

Flashover voltages for air gaps depend both on air humidity and relative air density. Insulation strength increases with absolute humidity up to the point where condensation forms on the insulator surfaces. Insulation strength decreases with decreasing air density.

For atmospheric conditions other than the standard conditions, IEEE Std 4-1995 provides methods to estimate the insulation strength.

At a given location, the variation with time of the relative air density, the absolute humidity, the humidity correction factor, and the product of the humidity correction factor and the relative air density may each be approximated by a Gaussian distribution. The standard deviations of these distributions are small and may be neglected. Thus, the insulation strength at nonstandard atmospheric conditions may be based on the average or mean values of the variables.

The design of line or substation insulation is universally based on rain conditions. Therefore, the atmospheric corrections are based on wet conditions. For station insulation, the BSL is defined for wet conditions. However, the BIL is tested under dry conditions under the premise that wet conditions do not severely degrade the insulation strength. Although this is not universally true, the wet BIL is assumed equal to the dry BIL.

For line insulation, the dry CFO is normally obtained from parametric tests. The wet CFO is estimated by multiplying the dry CFO with an experimentally determined correction factor.

4.4 Probability of disruptive discharge

There are no methods presently available for determining the probability of a disruptive discharge of non-self-restoring insulation. Therefore, the probability of a withstand is assumed to be 100% at or below the BIL and BSL. However, for stresses above the BIL and BSL level the probability of withstand is assumed to be zero.

For self-restoring insulation, the probability of flashover may be described by an insulation strength characteristic curve. This curve has two basic parameters: the CFO, corresponding to the 50% probability of flashover for a single impulse application, and the standard deviation (for coefficient of variation, σ_f/CFO). The insulation strength characteristic is modeled by a cumulative Gaussian distribution function and is considered valid to at least four standard deviations below the CFO. The actual truncation point, below which no flashover can occur, is not known. The insulation strength characteristic may be estimated by statistical test methods given in IEEE Std 4-1995. The statistical BIL or BSL, defined by the 10% probability of flashover, is mathematically defined as shown in Equation (3):

$$\text{BIL or BSL} = \text{CFO} \left[1 - 1.28 \frac{\sigma_f}{\text{CFO}} \right] \quad (3)$$

In addition, for evaluation of the switching surge flashover rate a statistical withstand voltage, V_3 , is used which is three standard deviations below the CFO. The truncation point is usually neglected. For self-restoring insulation, the value of the coefficient of variation is smaller for lightning impulses than for switching impulses. For lightning impulses, this coefficient is about 3%. For switching impulses for line or tower insulation, the coefficient increases to an average of about 5%. For station insulation, the coefficient of variation is generally assumed to be between 6% and 7%.

4.5 Influence of polarity and overvoltage shape

When the more highly stressed electrode in air is positively charged, the breakdown voltage is lower than if the electrode is negatively charged. For the majority of gaps, the high voltage conductor is more stressed and is the more irregularly shaped electrode. If the grounded electrode of a gap is more highly stressed, the dielectric strength to negative impulses is lower. For air-porcelain insulation, e.g., tower or line insulation, positive polarity impulses produce the lower insulation strength. For self-restoring station insulation, apparatus standards specify that the polarity which results in the lower insulation strength be used to establish the BIL or BSL. Although not specified, this polarity is almost universally positive.

The breakdown voltage of the insulation depends on the impulse shape. For switching impulses, the strength of external insulation depends primarily on the impulse front. Only in the case of pollution does the tail of the impulse become important. Both the crest and shape of the impulse affect the strength of internal insulation.

For switching impulses, there exists a critical wavefront (CWF) or time to crest value, which results in a minimum CFO. This CWF varies with the gap spacing. The approximate value of the CWF (μs), for positive polarity, is numerically equal to 50 times the gap spacing in meters. For larger gap spacing the change in the insulation strength at the CWF is more pronounced than for shorter gaps. For normal strike distances and clearances in high-voltage (HV) and extra high-voltage (EHV) systems, the CWF ranges from about 100–250 μs . In weak systems or in systems where low-side switching is employed, the wavefront time is in the range of 1000–2000 μs . In these cases, both the CFO and standard deviation increase, which results in about a 10% increase, in insulation strength.

The insulation strength for lightning impulses is normally only available for the standard lightning impulse, i.e., 1.2/50 μs . However, this wave shape seldom occurs on the utility system. Therefore, either some approximations or a mathematical model of the breakdown process are frequently necessary to evaluate the strength of the insulation for nonstandard wave shapes. This is of primary importance in evaluating the insulation strength for surges resulting from a backflash, and in evaluating the insulation strength of station insulation.

In contrast to the switching impulse, the tail or time to half value of the lightning impulse generally determines the CFO.

The flashover voltage of gaps, with close to uniform electric field distribution and the gaps under high-pressure gas in a GIS system, is almost independent from the applied voltage shape and duration.

4.6 Phase-phase and longitudinal insulation

The phase-phase and longitudinal insulation strength depends on the relationship of the voltage components at the two terminals. This dependency is particularly important for external insulation in EHV systems and for three-phase metal enclosed substations.

For phase-phase insulation, the test specified by IEC 60071-1 (1993) [B2]⁵ to establish the phase-phase BSL consists of two synchronized switching impulses, each of equal value, but of opposite polarity. The positive switching impulse applied to one electrode has the standard switching impulse wave shape. The negative switching impulse, applied to the other terminal, has a wave shape with a time to crest and a time to half value, which are not shorter than the wave shape on the positive polarity terminal. Therefore, in evaluating the required BSLs, the results of the calculation must be converted to the above test specifications of equal crest surge voltage on each of the terminals.

The standard deviations for either method of defining the phase-phase strength are essentially identical, about 5% for the usual gap, decreasing to about 2% for a 300–400 m conductor-conductor gap.

5. Performance/reliability criterion

The fundamental performance or reliability criterion is the acceptable failure rate. This criterion is based on the consequence of failure and on the expected life of the equipment. Therefore, the failure rate of transmission lines and substation equipment may be different.

5.1 Transmission lines

The performance/reliability criterion for lightning is normally specified as the number of flashovers per 100 km-years. For switching surges, the flashover rate is normally specified in terms of flashovers per number of switching operations. However, the highest magnitude switching surges normally occur when reclosing, which is normally caused by a fault associated with lightning. Thus, the two separate criteria may not be appropriate in specifying the line reliability. Another criterion, denoted as the storm outage rate, is the number of unsuccessful reclosures per year and is obtained by multiplying the lightning flashover rate for the line in units of flashovers per year by the switching surge flashover rate in terms of flashovers per switching operation. For example, assuming the lightning flashover rate to be two per year and the switching surge flashover rate to be one per 100 switching operations, the storm outage rate is two per 100 years assuming one reclosing operation per year. Both the storm outage rate and the lightning flashover rate may be important since the lightning fault creates voltages “dips” or depressions in power frequency voltage, which may affect customer power quality.

For transmission lines, lightning flashover rates vary with system voltage and may range from 0.5 for EHV systems to 20 per 100 km-year for HV systems. Although lines are being designed for switching surge flashover rates between 1 and 10 flashovers per 100 switching operations, due to other conservative assumptions, switching surge flashovers are relatively rare.

5.2 Substations

The commonly used reliability criterion for lightning is the MTBF.

⁵The numbers in brackets correspond to those of the bibliography in Annex A.

Because the consequence of failure within the station is greater than the consequence of a flashover of a single line, the station reliability criterion is higher than the line by a factor of 10. In addition, transformers, other wound devices, and equipment with non self-restoring insulation may be arrester protected due to the consequence of failure.

Different criteria are usually applied to air- and gas-insulated stations. For example, the MTBF for air-insulated stations varies between 50 and 200 years, whereas for the gas-insulated station, the MTBF has been set as high as 800 years. The basis for the increase is the consequence of failure in the gas-insulated station that may require significant outage and repair times.

6. Insulation coordination design

6.1 Design procedures for continuous power frequency voltage and temporary overvoltages

Insulation must withstand the maximum system voltage over the service life of the equipment. Insulation must either withstand or be protected against temporary overvoltages having a magnitude equal to the short duration, power frequency overvoltages.

6.1.1 General

When contamination is present, the response of external insulation to power frequency voltages becomes important and may dictate external insulation design. Flashovers generally require the following two conditions:

- Contamination on the insulator's surface, and
- Wetting of insulator's surface by a light rain, mist, dew, or fog, without washing and removing the contamination.

This mixture of contaminants and moisture produces a conducting film, such that a current flows through the contamination layer. At locations such as the narrow portion of a post insulator or in the rib area underneath a line insulator, the current is concentrated to a degree that the layer dries creating dry bands. The total phase-ground voltage appears across these small dry bands, and dry band arcing occurs. These arcs gradually grow outward and eventually the insulator flashes over.

The power frequency flashover voltage is considered to be the same for 60 Hz and for 50 Hz.

6.1.2 Design approach

The stress placed across the insulators is the phase-ground power frequency voltage. The contamination decreases the insulators' power frequency voltage strength. The deterministic design rule is to set the statistical withstand voltage (V_3) equal to the maximum phase-ground voltage (E_m), which includes temporary overvoltages as shown in Equation (4):

$$V_3 = E_m \tag{4}$$

where

$$V_3 = \text{CFO} \left[1 - 3 \frac{\sigma_f}{\text{CFO}} \right]$$

The CFO is the power frequency flashover voltage under contaminated conditions and the coefficient of variation, σ_f/CFO , is assumed to be 10%.

6.1.3 Contamination severity

The contamination is separated into the following two general classes:

- a) *Industrial*: The industrial contamination is caused by particles driven by the wind and deposited on the insulator surface. The contamination may be dust from road or rural areas, cement, fly ash, limestone, etc. These materials contain salt and form a conducting layer when wetted.
- b) *Sea*: Salt-water spray driven by the wind can also contaminate insulating surfaces. This forms a conducting layer. In this case, the contamination and wetting occurs simultaneously.

The degree or severity of the contamination is specified in two ways

- Industrial contamination, with the amount of salt on the surface, is normally specified in units of mg/cm^2 .
- Sea contamination, the amount of salt per volume of water, is normally specified in grams per liter or in kg per cubic meter of water.

To standardize for industrial contamination, the equivalent salt deposit density (ESDD) is used, defined as the equivalent amount of NaCl, which would yield the same conductivity as the contaminant. Another method of measuring industrial contamination severity, used in Germany, is to measure the conductivity of the moistened layer. The appropriate measurement unit is the microsiemens, μS . IEEE Std 4-1995 gives the method of collecting the contaminate and the measurement of contamination level.

The general site severity and its definition per IEEE Std 1243-1997 [B9] and CIGRE Technical Bulletin 63 [B10] are shown in Table 4 in terms of the ESDD. The layer conductivity is approximately 100 times the ESDD and the salt spray salinity is 140 times the ESDD. For example, the equivalent layer conductivity and the equivalent salt spray salinity for an ESDD of 0.05 is $5 \mu\text{S}$ and $7 \text{ kg}/\text{m}^3$, respectively.

Table 4—Contamination site severity

Site severity	ESDD, mg/cm^2	
	CIGRE	IEEE
None	0.0075–0.015	
Very light	0.015–0.03	0–0.03
Light	0.03–0.06	0.03–0.06
Average/moderate	0.06–0.12	0.06–0.10
Heavy	0.12–0.24	> 0.10
Very heavy	0.24–0.48	
Exceptional	>0.48	

6.1.4 Insulation strength—IEEE recommendations

The insulation strength (kV/m) is defined as the ratio of the withstand voltage and connecting length. The withstand voltage is determined by the clean fog test method. Table 5 gives the power frequency voltage

strength of insulator strings at various contamination levels. The standard suspension insulator [146 mm × 254 mm (5.75" × 10")] has a leakage distance of 292 mm (11.5").

Table 6 gives the required number of standard insulators in a string for system voltages from 138 kV–765 kV. To be noted is that, at 345 kV, a minimum of 15 units in I-string, has been used with success. At 500 kV, a minimum of 22 units in V-string, and at 765 kV, a minimum of 30 units in V-string has been used successfully.

Table 5—Power frequency voltage strength of insulator strings (kV/m connecting length)

Classification	Severity, mg/cm ²	Standard units (kV/m) 5 3/4" × 10"		High-leakage units
		I-string	V-string	
Very light	0.03	86.9	98.6	91–99
Light	0.06	67.5	82.0	74–88
Moderate	0.10	59.3	74.8	64–82
Heavy	0.40	49.3	66.0	56–73

Table 6—Number of standard units required

System voltage, kV	Number of standard units for a contamination severity I-strings/ V-strings			
	Very light	Light	Moderate	Heavy
138	6/6	8/7	9/7	11/8
161	7/7	10/8	11/9	13/10
230	11/10	14/12	16/13	19/15
345	16/15	21/17	24/19	29/22
500	25/22	32/27	37/29	44/33
765	36/32	47/39	53/42	64/48

6.1.5 Insulation strength—CIGRE recommendations

The CIGRE recommendation specifies the insulation strength by the specific leakage distance, which is the creepage or leakage distance per kV system voltage. The specific leakage distance is determined by different contamination test methods. The recommended specific leakage distance (L_C) in cm/kV withstand voltage is given by Equation (5), Equation (6), and Equation (7) for the three most frequently used test methods.

For the Salt Fog (English) method:

$$L_C = 2.34 S_a^{0.224} = 7.09 \text{ ESDD}^{0.224} \tag{5}$$

where

S_a is the amount of salt in the water, used for the test in kg/m³

For the Kieselguhr (German) method:

$$L_C = 1.42 \sigma_w^{0.387} = 8.15 \text{ ESDD}^{0.387} \tag{6}$$

where

σ_w is the insulator surface conductivity in μS

For the Fog Withstand (Japanese) method:

$$L_C = 7.14 \text{ ESDD}^{0.246} \quad (7)$$

The first formulation of each equation is given in units for which the test method was devised. The second formulation is a conversion to the ESDD measurement, mg/cm^2 . These values are based on a withstand voltage defined at the 5% to 10% probability of flashover plus a safety margin of 25%. These equations may be used for all types of porcelain insulators; that is they are not confined to the normal or standard unit. However, they are not applicable to nonceramic, composite-type insulators.

6.1.6 Insulation strength—IEC recommendation

IEC 60071-2 (1996) [B3] recommends the creepage distance for ceramic or glass insulators for different contamination severity. However, the recommendation does not cover some environmental situations, such as ice in heavy pollution, heavy rain, arid areas, etc. The recommended creepage distances are listed in Table 7 as mm/kV rms line-ground.

Table 7—IEC 60071-2 recommended creepage distances

Pollution level	Examples of typical environments	Minimum specific creepage distance mm/kV
I Light	<ul style="list-style-type: none"> — Areas without industries and with low density of houses equipped with heating plants — Areas with low density of industries or houses but subjected to frequent winds and/or rainfall — Agriculture areas^a — Mountainous areas — All these areas shall be situated at least 10 km to 20 km from the sea and shall not be exposed to winds directly from the sea^b 	27.7
II Medium	<ul style="list-style-type: none"> — Areas with industries not producing particularly polluting smoke and/or with average density of houses equipped with heating plants — Areas with high density of houses and/or industries but subjected to frequent winds and/or rainfall — Areas exposed to wind from the sea but not too close to coasts (at least several kilometers distant)^b 	34.6
III Heavy	<ul style="list-style-type: none"> — Areas with high density of industries, and suburbs of large cities with high density of heating plants producing pollution — Areas close to the sea or in any case exposed to relatively strong winds from the sea^b 	43.3
IV Very heavy	<ul style="list-style-type: none"> — Areas generally of moderate extent, subjected to conductive dusts and to industrial smoke producing particularly thick conductive deposits — Areas generally of moderate extent, very close to the coast and exposed to sea spray or to very strong and polluting winds from the sea — Desert areas, characterized by no rain for long periods, exposed to strong winds carrying sand and salt, and subjected to regular condensation 	53.7

^aUse of fertilizers by spraying or the burning of crop residues can lead to a higher pollution level due to dispersal by wind.

^bDistances from seacoast depend on the topography of the coastal area and on the extreme wind conditions.

The analysis of the data in Table 5, Table 6, and Table 7 shows that the IEC data compares favorably with the IEEE data. This is summarized in Table 8.

Table 8—Comparison of contamination requirements, IEEE vs. CIGRE specific leakage distance for I-strings

ESDD mg/cm ²	CIGRE mm/kV (line to ground)			IEEE mm/kV
	Salt Fog	Kieselguhr	Fog Withstand	Clean fog
0.03	32	22	30	23
0.06	38	29	36	30
0.10	42	35	41	34
0.40	58	60	57	41

6.1.7 Comparison

Table 8 shows that except for the 0.40 mg/cm² level of contamination, the Kieselguhr method results in values close to the IEEE method. The other methods require higher values of specific leakage distance and consequently require more standard insulators. The lowest level of 0.03, the Salt Fog and Fog Withstand methods would require 23 and 22 insulators at 345 kV whereas the Kieselguhr or IEEE methods require 16 units. Therefore, except for the Kieselguhr method, the CIGRE recommended leakage distances are very conservative.

The methods presented in 6.1.5 and 6.1.6 are provided for information. The final contamination design is often using one of these methods in combination with operational experience.

6.1.8 Switching impulse and lightning impulse strength

Because of the short duration of the impulse, the lightning impulse strength is unaffected by contamination. The decrease in the switching impulse strength is a function of the degree of contamination. For heavy contamination, the strength is equal to about twice the crest power frequency strength and increases to three times the crest power frequency strength for light contamination.

6.1.9 Effect of elevation

The above values are applicable to sea level conditions. The number of insulators, N_A , at other elevations is approximately, as shown in Equation (8):

$$N_A = N_g e^{\frac{A}{14}} \quad (8)$$

where

N_g is the number of insulators at sea level and A is the elevation in km

6.1.10 Methods to improve performance

The single most important parameter of contamination performance in ceramic insulators is creepage or leakage distance. The increase of leakage distance generally improves performance. The goal is to have accept-

able performance with the shortest possible coupling distance and a strike distance, which is equal to or less than that required for switching or lightning. Another method to improve performance is the change of insulator surface properties such as room temperature vulcanizing (RTV) coatings (hydrophobic surface) or periodic washing of insulators.

Methods to improve performance include:

- a) *High leakage insulators*: Insulators such as the fog-type units offer increased leakage distance pu of insulator length. Leakage distances to length ratios of 2.9 to 4.5 are available.
- b) *Nonceramic insulators*: These units have hydrophobic surfaces, which generally improve performance. The improvement in terms of the withstand voltage per connected length is 40% to 100%.
- c) *Greasing*: The insulators may be greased with silicon or petroleum grease. Grease must be removed and reapplied periodically. The greasing provides a hydrophobic and pollution absorbing surface. However, after a few years of service the pollution (dust) saturates the grease, which requires removal and reapplication.
- d) *Washing/cleaning*: The pollution is removed from the insulator's surface by high pressure water or air-driven dry abrasive material, such as ground walnut or corncobs and limestone.
- e) *RTV coatings*: The porcelain insulators are coated with room temperature vulcanized silicon rubber, which produces a hydrophobic surface and improves performance.
- f) *Insulators with semiconducting glaze*: A thin layer of resistive glaze covers the insulators. The leakage current heats the insulator surface, preventing condensation and wetting, which improves performance.

6.2 Procedures for switching overvoltages (SOV)

6.2.1 Transmission lines, phase-ground

6.2.1.1 General

The switching surge flashover rate (SSFOR) of a transmission line is determined by calculating the probability that the stress along the line exceeds the line insulation strength. The flashover rate is shown in Equation (9):

$$SSFOR = \frac{1}{2} \int_{E_1}^{E_m} f_s(V) \left[1 - \prod_{i=1}^n q_i \right] dV \quad (9)$$

where

- SSFOR is the flashover rate in terms of flashover per number of switching operations
- $f_s(V)$ is the probability density function of the switching overvoltages at the open end of the line
- q_i is the probability of no flashover (withstand) at the i -th tower or is $(1-p_i)$ where p_i is the probability of flashover for a specific SOV being considered
- n is the number of towers

The equation may be visualized from Figure 1. The probability density function at the open end of the line is illustrated in Figure 1 by the solid line, where E_1 is the minimum SOV usually set at 1.0 pu of crest system line-ground voltage and E_m is the maximum SOV. The SOV density function may be obtained through the use of a transient computer program where the breakers are randomly switched within their pole closing

span. The resulting randomness of the switching overvoltages is approximated by the SOV density function. This function is usually a Gaussian (also known as a normal) density function although other functions, such as the extreme value density function, have been used. For situations where no surge arresters are employed at the ends of the line, the SOVs at the open end of the line are largest, whereas when arresters are employed, the maximum SOVs occur at about 1/3 to 1/4 of the line length from the arrester.

The $1/2$ preceding the integral recognizes that the SOV distribution is constructed for both positive and negative polarity SOVs and that the negative polarity insulation strength is sufficiently larger than the positive polarity strength and it may be neglected.

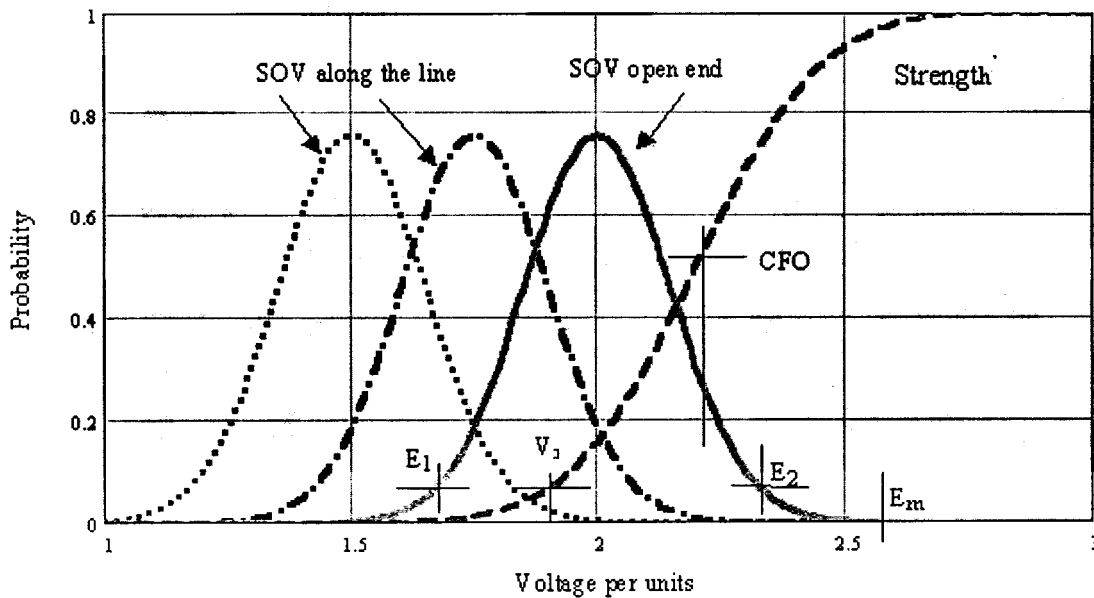

Figure 1—Switching overvoltage (SOV) strength characteristics and SOV densities on the line

6.2.1.2 Stress

The Gaussian SOV density function is characterized by the statistical SOV, denoted by E_2 , which has a 2% probability to be equaled or exceeded, i.e., E_2 is equal to the mean plus 2.05 standard deviation, and by σ_o/E_2 where σ_o is the standard deviation. Typical values for E_2 and σ_o/E_2 are provided in Table 1 with breakers equipped with and without preinsertion resistance.

6.2.1.3 Strength

The strength characteristic of the line or tower insulation may be modeled as a Gaussian cumulative distribution function, which is also shown in Figure 1. It is characterized by the mean value (CFO) and by the coefficient of variation, (σ_f/CFO) . An additional parameter is also used which is denoted as V_3 , defined as the voltage at 3 standard deviation below the CFO or, as shown in Equation (10):

$$V_3 = CFO - 3\sigma_f = CFO \left(1 - 3 \frac{\sigma_f}{CFO} \right) \quad (10)$$

The distribution is considered applicable to at least $4 \sigma_f$ below the CFO. The CFO, obtained from tests in high-voltage laboratories, may be estimated by use of Equation (11) and Equation (12):

$$\text{CFO} = k_g \frac{3400}{1 + \frac{8}{S}} \quad (11)$$

where

S is the strike distance in meters
 k_g is the gap factor
 CFO is in kV

The gap factor for a V-string insulator in the center phase of a tower, i.e., the tower window, can be calculated by Equation (12):

$$k_g = 1.25 + 0.005\left(\frac{h}{S} - 6\right) + 0.25\left(e^{-\frac{8w}{S}} - 0.2\right) \quad (12)$$

where

h is the phase conductor height at the tower and w is the tower width, both in meters

For a lattice steel tower, the gap factor is about 1.20, while for a steel pole, the gap factor increases to about 1.25.

For the V-strings on the outside phase, k_g is about 1.08 times the gap factor of the center phase.

For V-strings, the insulator string length should be a minimum of 1.05 times the strike distance to the structure.

For I-strings, which are not restrained from movement, the gap factor is considered identical to that for V-strings on the outside phase. However, the strike distance is the smallest of the following:

- a) The strike distance to the upper truss,
- b) The strike distance to the tower side, and
- c) The insulators string length divided by 1.05.

For insulator strings not constrained from movement, wind may move the conductor closer to the tower side, thus decreasing the strike distance. The movement can be estimated by calculating the swing angle, α , as shown in Equation (13):

$$\alpha = \tan^{-1}(k_1 v^{1.6}) \quad (13)$$

where

$$k_1 = 1.13810^{-4} \frac{D/W}{V/H}$$

where

D is the conductor diameter, in cm
 W is the conductor weight, in kg/m
 V is the vertical or weight span
 H is the horizontal or wind span
 v is the wind speed, in km/h

For high voltage lines, 60% of the 100-year mean recurrence wind is used. The 100-year wind is the wind speed with a mean recurrence interval of 100 years.

The CFO in Equation (11) is for dry, positive polarity conditions and for the critical wavefront. For “long” wave fronts on the order of 1000 μ s or greater, which may occur in weak systems or for low-side switching, the CFO increases by about 10%. For wet conditions, which is the usual design condition, the CFO may decrease by 1% to 8%. A suggested value is a decrease of 4%.

The coefficient of variation for line insulation averages about 5% and thus V_3 is 0.85 CFO.

The prior equations for the CFO are for standard atmospheric conditions. For elevations other than sea level, the mean value of the CFO decreases as a function of elevation by using Equation (14):

$$\text{CFO}_A = \delta^m \text{CFO}_S \quad (14)$$

where

CFO_S is the CFO for standard atmospheric conditions
 δ is the relative air density
 CFO is the CFO for the relative air density, δ

The relative air density is calculated by using Equation (15):

$$\delta = e^{-\frac{A}{8.6}} \quad (15)$$

where

A is the elevation in km
 m is a constant, which is defined by

$$m = 1.25 G_0(G_0 - 0.2)$$

where

$$G_0 = \frac{\text{CFO}_S}{500S}$$

S is the strike distance in meters

6.2.1.4 Sensitivity

For the Gaussian density function, the SSFOR in flashovers per 100 switching operations is shown by the curves of Figure 2 as a function of the strength/stress ratio of V_3/E_2 . These curves are constructed for a line consisting of 500 towers with identical SOV at each tower. The SSFOR is insensitive to the number of towers between 200 and 1000, only producing about a 2% difference in SSFOR.

However, the SOV profile along the line has a more significant effect. The SSFOR decreases by 6% when the ratio of the open end SOV to the switched end SOV is 1.6. Since a flat voltage profile is assumed, Figure 2 provides conservative estimates of the SSFOR.

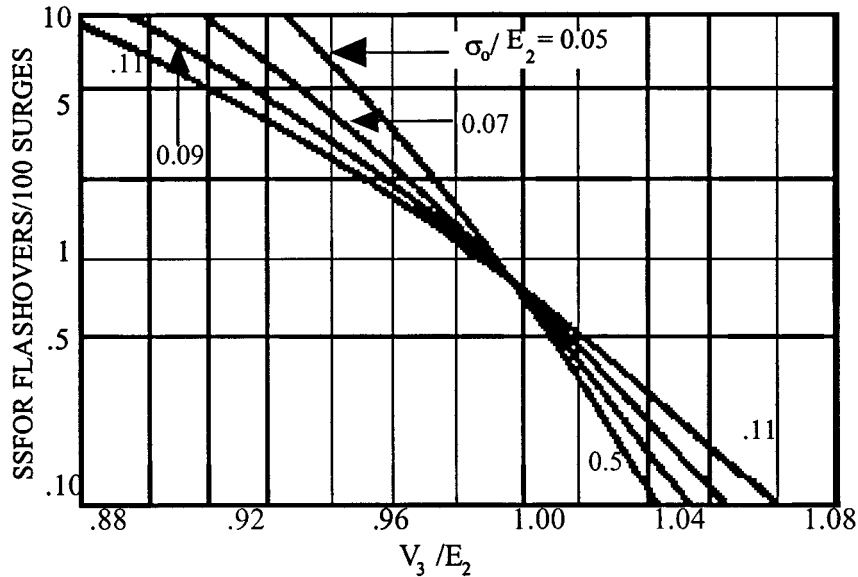

Figure 2—SSFORs for 500 towers, flat voltage profile

6.2.1.5 Design criteria

Acceptable practice is to design for approximately one flashover per 100 switching operations. However, a better design criteria is to consider all switching operations (energization, reclosing with trapped charge, etc.) and the expected number of operations per year.

6.2.2 Transmission lines—phase-to-phase

6.2.2.1 General

For lines with grounded metal structures between the phase conductors, the phase-to-ground strike distance dictates the SSFOR. For compact line designs, where insulators separate phases, the phase-phase strike distance may dictate the line design. See Figure 2.

6.2.2.2 Self-restoring insulation

The phase-phase switching impulse insulation strength of transmission lines (air or insulator) is a function of the components of the phase-phase switching impulse. The phase-phase critical flashover voltage (CFO_p) decreases as the positive component of voltage increases. Defining the positive component of the phase-phase switching impulse as V^+ and the negative component as V^- , the CFO of the positive component, (CFO^+) is, as shown in Equation (16):

$$CFO^+ = CFO_0 - K_L V^- \quad (16)$$

where

$$K_L \text{ is } 0.62\text{--}0.7$$

Figure 3 shows the CFO^+ versus V^- relation.

From this equation, the phase-phase CFO_p is, as shown in Equation (17):

$$\text{CFO}_p = \text{CFO}_0 + (1 - K_L)V^- \quad (17)$$

where

K_L is about 0.68 for transmission lines, and the CFO_0 (for $V^- = 0$) is approximately:

$$\text{CFO}_0 = 1.26 \frac{3400}{1 + \frac{8}{S_p}}$$

where

CFO_0 is the critical flashover voltage that belongs to a $\sigma_f / \text{CFO}_0 = 0.025$ standard deviation, and S_p is the phase-phase clearance in meters

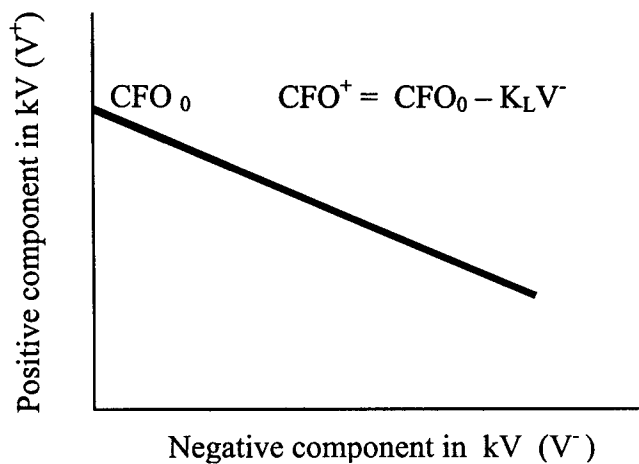

Figure 3—Positive polarity, phase-phase insulation strength as a function of the negative polarity switching impulse V^-

Because the switching impulse strength is dependent on the components of the phase-phase switching impulse, both the positive and negative SOVs must be known. Since there are 3 types of SOVs, any two of the SOVs may be collected, the other SOV being determined by subtraction or addition. That is, collection of the SOVs may be

- The positive and negative polarity SOVs,
- The positive and phase-phase SOVs, or
- The negative and phase-phase SOVs.

In collection of the positive and negative SOVs, two time instants are normally considered

- The time for which the maximum positive SOV occurs
- The time for which the maximum phase-phase SOV occurs

In general, for air clearances the time of the maximum positive SOV is more severe, whereas for non-self-restoring insulation the time for the maximum phase-phase SOV is more severe. In most cases, the SOV densities for both time instants are sufficiently close so that, as an approximation, either time instant may be employed. Generally, since the maximum positive SOVs are used for phase-ground insulation coordination, it is convenient to collect the phase-phase SOVs at the time of the maximum positive SOVs. Assuming Gaussian SOV density functions, the phase-phase SSFOR, i.e., the SSFOR_p , may be estimated as shown in Equation (18):

$$SSFOR_p = \frac{1}{2} \int_{-\infty}^{+\infty} f(V_Z) \left[1 - \prod_{i=1}^n q_i \right] dV_Z \quad (18)$$

where

$f(V_Z)$ is the probability density function of V_Z

$$V_Z = (1 - K_L)V^+ + K_L V_p$$

where

V^+ is the positive phase-ground SOV

V_p is the phase-phase SOV

The parameters of V_Z may be obtained from the mean and standard deviations of V^+ and V_p , as shown in Equation (19) and Equation (20).

$$\mu_z = (1 - K_L)\mu^+ + K_L\mu_p \quad (19)$$

$$\sigma_z = \sqrt{[(1 - K_L)\sigma^+]^2 + [K_L\sigma_p]^2 + 2\rho(1 - K_L)\sigma^+\sigma_p} \quad (20)$$

where

ρ is the correlation coefficient between the positive and phase-phase SOVs and conservatively, is usually set to unity

The curves of Figure 4 show the phase-phase SSFOR as a function of the ratio of V_{30} (V_3 for CFO₀) divided by E_{2z} (E_2 for V_z), assuming a correlation coefficient of one. As for the phase-ground SSFOR, a V_{30}/E_{2z} ratio of one produces a phase-phase SSFOR of about 1/100, regardless of the value of σ_z/E_{2z} .

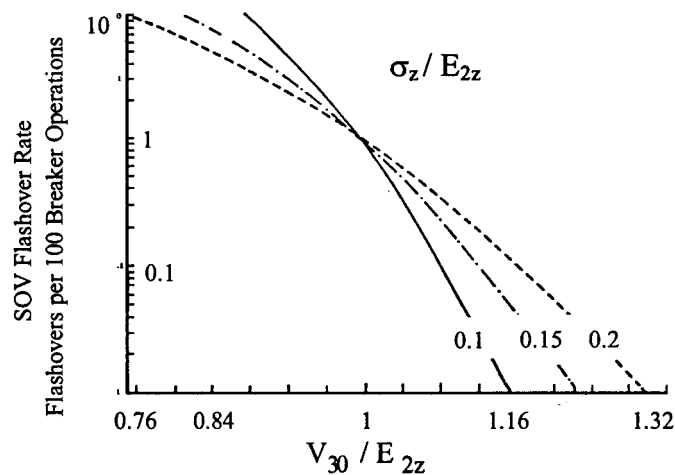

Figure 4—Estimating curves for phase-phase SSFOR, 500 towers flat voltage profile

6.2.3 Substations phase-ground

The objective is to determine the phase-to-ground BSL and the phase-ground clearances. The procedure differs for self- and non-self-restoring insulation. For self-restoring insulation (disconnecting switches and bus

support insulators), a statistical BSL exists and the insulation's strength characteristics may be defined by CFO and σ_f . In contrast, for non-self-restoring insulation (the internal insulation of the transformer or bushing), the BSL is a single valued function. The probability of failure is assumed to be 100%, when the voltage exceeds the BSL.

6.2.3.1 Self-restoring insulation

For station insulation the SSFOR may be estimated by use of the equations presented in 6.2.1. In the station, identical SOVs impinge on all electrically connected insulation and the insulation strengths of various equipments may not be equal. The SSFOR can be calculated using Equation (21):

$$\text{SSFOR} = \frac{1}{2} \int_{E_1}^{E_m} f_s(V) \left[1 - \prod_{i=1}^n q_i \right] dV \quad (21)$$

where

$f_s(V)$ is the probability density function of the SOVs

q is the probability of no flashover for each self-restoring insulation

Often the task is not to determine the SSFOR but to estimate the BSLs and clearances given a design value of SSFOR. Under this assumption, all insulation strengths are considered equal, i.e., all values of V_3 are equal. Thus Equation (21) is simplified, as shown in Equation (22):

$$\text{SSFOR} = \frac{1}{2} \int_{E_1}^{E_m} f_s(V) [1 - q^n] dV \quad (22)$$

Because the number of parallel insulations is small, the approximations of 6.2.1 are conservative, and the strength-stress ratios of Table 9 are suggested. For self-restoring insulation, the suggested value of σ_f/CFO is 0.07. Table 9 indicates that the presence of line entrance arresters decreases the standard deviation of the SOV density function, and therefore a larger value of strength-stress ratio is required for the equivalent SSFOR.

Table 9—Typical values of V_3/E_2 for phase-ground self-restoring insulation: $\sigma_f/\text{CFO} = 0.07$, $n = 10$

SSFOR	Condition	σ_o/E_2	V_3/E_2
1/100	No arrester	0.10–0.15	0.90
1/100	With arrester	0.01–0.03	0.96
1/1000	No arrester	0.10–0.15	1.00
1/1000	With arrester	0.01–0.03	1.02

The value of E_2 is either the switching impulse discharge voltage of the arrester or the value of E_2 without the arrester, whichever is lower. The design value of the SSFOR has been generally in the range of one flashover per 100 switching operations, i.e., 1/100. However, because the consequence of flashovers or failures of station is generally considered more severe than for the transmission line, the SSFOR of the station is sometimes set lower than that for lines, e.g., 1/1000.

The SSFOR of the station insulation is generally dictated by the insulation having the lowest insulation strength. For example, for $n = 5$, decreasing the BSL by 10% increases the SSFOR by 360%, while decreasing only one of the insulations by 10%, increases the SSFOR by 200%.

Typical BSL values are given in IEEE Std 1313.1-1996. Specific values for station apparatus are given in various apparatus standards.

BSLs of post insulators and disconnecting switches are not provided by standards. As an approximation, the BSL may be obtained by using Equation (23):

$$\text{BSL} = 1.07 \frac{3400}{1 + \frac{8}{H_i}} \quad (23)$$

where

H_i is the insulator height in meters

The switching impulse strength of air gaps may be estimated by using Equation (24):

$$\text{CFO} = k_g \frac{3400}{1 + \frac{8}{S}} \quad (24)$$

where

k_g is the gap factor

S is the strike distance in meters

Typical gap factors used for station clearances are presented in Table 10. Where the gap factor for a specific configuration is unknown, then a value of 1.30 is suggested.

Table 10—Typical value of gap factors, k_g for phase-ground insulation

Gap configuration	k_g , gap factor
Rod-plane	1.00
Rod-rod (vertical)	1.30
Rod-rod (horizontal)	1.35
Conductor-lateral structure	1.30
Conductor-plane	1.15

Using a ratio of V_3/E_2 from Table 9 and knowing a value of E_2 , the required CFO value is calculated by using Equation (10). Equation (25) gives the obtained CFO value.

$$\text{CFO} = V_3 + 3\sigma_f \quad (25)$$

The required clearance is determined by calculating S from Equation (24).

The required BSL is calculated from Equation (3), which is repeated here as Equation (26).

$$\text{BSL} = \text{CFO} \left[1 - 1.28 \left(\frac{\sigma_f}{\text{CFO}} \right) \right] \quad (26)$$

6.2.3.2 Non-self-restoring insulation

For non-self-restoring insulation (transformer and the internal insulation of the bushing), the above statistical procedure cannot be used. The insulation strength is specified by a conventional BSL. The required BSL is the arrester switching impulse discharge voltage multiplied by a protective ratio. The minimum protective ratio is 1.15%; however, larger margins have been used.

6.2.3.3 Example

Assume a 500 kV (550 kV max.) station, which is to be designed for an SSFOR of 1/100. First, assume that no station entrance arresters are to be used and that the value of E_2 is 808 kV and the standard deviation is 56.6 kV, because $\sigma_f/\text{CFO} = 0.07$. Assume also that the station is at sea level. From Table 9, the required ratio of V_3/E_2 is 0.90 and therefore the required V_3 is 727 kV. From Equation (25), the required CFO is 920 kV. Also for Equation (25) and Equation (26), the required BSL is 837 kV. The phase-ground clearance can be calculated using Equation (24), with a k_g of 1.30, as seen in Equation (27).

$$S = \frac{8}{\frac{3400k_g}{\text{CFO}} - 1} = \frac{8}{\frac{3400 \cdot 1.3}{920} - 1} = 2.10 \text{ m} \quad (27)$$

Now assume a 318 kV MCOV station entrance arrester has a switching impulse discharge voltage of 775 kV. From Table 9, the ratio of V_3/E_2 is 0.96 so that the V_3 is 744 kV and the calculated CFO is 942 kV. Thus, the required BSL becomes 858 kV. The phase-ground clearance is now 2.17 m. Presently used clearances in 500 kV stations are in the range of 4.0 m. For this example, the arrester does not decrease the required clearance or the BSL. This would change if the value of E_2 were larger, e.g., an E_2 of 2.8 pu. If the elevation of the station were greater than sea level, corrections to the insulation strength required would be similar to those required by transmission lines.

The minimum required BSL of the internal insulation of a transformer and bushing is 1.15 (775) or 891 kV.

It has to be noted that the safety clearance has to be determined from National Electrical Safety Code[®] (NESC[®]), Table 124-1. For EHV stations as in this example, the safety clearances must satisfy the clearance requirements based on the standard BSL and standard BIL.

6.2.4 Substations phase-phase

6.2.4.1 General

Phase-phase BSLs have not been established for apparatus in the present IEEE apparatus standards. However, IEC 60071-1 (1993) [B2] specifies phase-phase BSLs that are presented in Table 11. The test for the phase-phase BSL consists of the application of equal positive and negative switching impulses to each electrode. For example, for a phase-phase BSL of 1275 kV, a 637.5 kV positive polarity impulse is applied to one electrode coincident with the application of a 637.5 kV negative polarity impulse to the other electrode. Only the selections of the phase-phase clearances are discussed here, because the phase-phase BSL_p is not specified.

Selection of the phase-phase clearances uses the same equations and concepts as transmission lines. For the selection of the phase-ground clearance, Table 12 may be used. The value of $V_{3\sigma}/E_{2Z}$ is selected from Table 12 for alternate values of the phase-phase SSFOR.

Typical value for E_{2p}/E_2 is 1.6. E_{2Z} is about 1.35 E_2 or approximately 2.4 pu for an E_2 of 1.8 pu and about 3.8 for an E_2 of 2.8 pu. For these same values of E_2 , σ_z/E_{2Z} is about 0.10 and 0.14, respectively.

The insulation strength for air gaps may be specified by their phase-phase gap factor, k_{gp} , and by the value of K_L . The typical values are as presented in Table 13.

Table 11—BIL and BSL from IEC 60071-1 (1993) [B2]

Max. system voltage, kV	Phase-ground BSL, BSL _g , kV	Ratio BSL _p /BSL _g	BIL, kV
300	750 850	1.50 1.50	850 or 950 950 or 1050
362	850 950	1.50 1.50	950 or 1050 1050 or 1175
420	850 950 1050	1.50 1.50 1.50	1050 or 1175 1175 or 1300 1300 or 1425
550	950 1050 1175	1.50 1.60 1.60	1175 or 1300 1300 or 1425 1425 or 1550
800	1300 1425 1550	1.60 1.70 1.70	1550 or 1800 1800 or 1950 1950 or 2100

Table 12—Suggested values of V_{30}/E_{2Z} phase-phase self-restoring insulation $\sigma_f/CFO_0 = 0.035$, $n = 1$, Gaussian distribution

SSFOR	σ_Z/E_{2Z}	V_{30}/E_{2Z}
1/100	0.01–0.15	0.94
0.5/100	0.01–0.15	0.96
0.1/100	0.01–0.05 0.05–0.15	0.98 1.04
0.05/100	0.01–0.03 0.03–0.15	1.04 0.99

Table 13—Gap factors for phase-phase switching impulses

Gap configuration	K_L	k_{gp}	σ_f/CFO_0
Conductor-conductor, 10 m	0.67	1.35	0.035
Rod-rod	0.67	1.35	0.05
Conductor-conductor, 300 to 400 m	0.68	1.26	0.02
Crossed conductors	0.62	1.53	0.05
Ring-ring or large electrodes	0.70	1.53	0.05
Asymmetrical gaps rod-conductor	0.67	1.21	0.05

The CFO is calculated by using Equation (28).

$$CFO_0 = k_{gp} \frac{3400}{1 + \frac{8}{S_p}} \quad (28)$$

where

S_p is the phase-phase clearance

The procedure consists of selecting the value of V_{30}/E_{2Z} from Table 12, and with the value of E_{2Z} , the clearance, S_p , may be obtained from Equation (28) using Equation (29):

$$V_{30} = CFO_0 \left[1 - 3 \left(\frac{\sigma_f}{CFO} \right) \right] \quad (29)$$

6.2.4.2 Example

As for example in 6.2.3.3, assume a 500 kV station. Using the same data as in example 6.2.3.3, then E_{2Z} is equal to 1091 kV. From Table 12, designed for an SSFOR of 1/100, the required ratio, V_{30}/E_{2Z} is 0.94, therefore $V_{30} = 1025$ kV and CFO_0 for the 10 m conductor-conductor gap is 1145 kV. Using Equation (28) and the gap factors of Table 13, the required phase-phase clearances are shown in Table 14.

Table 14—Phase-phase clearances calculated in example 6.2.4.2

Gap configuration	Spacing/clearance, meters
Conductor-conductor, 10 m	2.66
Rod-rod	2.85
Conductor-conductor, 300 to 400 m	2.73
Crossed conductors	2.87
Ring-ring or large electrodes	2.42
Asymmetrical electrodes or rod-conductor	2.32

The conductor-conductor, 10 m length, may be used for the bus-bus clearance. The ring-ring applies to the spacing between large grading rings. As an example, these types of rings are used on high-voltage (500 kV) current transformers. The rod-conductor applies to the top of a vertical-break-disconnecting switch to the upper bus. The crossed-conductors apply to the spacing between the upper and lower buses. The rod-rod applies to the spacing between small diameter grading rings. As an example, these types of rings are used at medium voltage (69 kV).

6.3 Procedures for lightning overvoltages

6.3.1 Transmission lines

The lightning performance of transmission lines is the sum of the following:

- The shielding failure flashover rate (SFFOR), and
- The backflash rate (BFR).

Both of these flashover rates are linearly dependent on the lightning ground flash density measured in flashes per square km-year.

Two primary methods, IEEE Std 1243-1997 [B9] and CIGRE Technical Bulletin 63 [B10] methods are in use to estimate the BFR and the SFFOR.

These methods are described in the literature and computer programs are available to perform calculations, consequently, in this guide, the methods are not discussed.

6.3.1.1 Shielding failures

Overhead shield wires are located above the phase conductors to prevent flashovers caused by lightning flashes terminating on the phase conductor. In addition to the ground flash density, the SFFOR is a function of the tower insulation strength and the shielding angle. The shielding angle is defined as the angle whose tangent is the horizontal distance between the shield wire and the phase conductor, divided by the difference between the height of the shield wire and the phase conductor. Lightning flashes that produce currents less than that required for flashover form the basis of shielding design. The critical current, I_c , is shown in Equation (30):

$$I_c = \frac{2CFO}{Z} \quad (30)$$

where

CFO is the negative polarity lightning impulse CFO that is approximately 605 kV/m of strike distance or insulator length

Z is the surge impedance of the phase conductors, which is typically between 350–500 Ω

If the shielding angle is set so that lightning flashes with currents greater than the critical current do not terminate on the phase conductor, the SFFOR is assumed to be zero. Usually, the shielding angle is determined for the first stroke of the flash because it usually has a higher current than the subsequent strokes. However, even though the first stroke does not result in a flashover, subsequent strokes may have larger currents that can produce flashover.

The typical design value of the SFFOR is approximately 0.05 flashover/100 km-years. Since the SFFOR is a function of the ground flash density, the required shielding angle increases as the ground flash density decreases. Thus, in areas of low ground flash density, only a single shielding wire may be required, whereas in areas of higher ground flash density, two shielding wires may be necessary.

In the past, shielding angles of 30° were used with success for tower heights of about 25 m. Shielding angles in the range of 12° or less are required for tower heights of about 50 m.

6.3.1.2 Backflash

A lightning stroke terminating on the shield wires produces a voltage across the insulation. If the stroke current is of sufficient magnitude, the voltage produced becomes greater than the insulation strength and a flashover or backflash occurs.

The primary parameters that effect the backflash rate (BFR) and that are under the control of the designer are the following:

- a) The strike distance and insulator length.

- b) The tower footing resistance. If the desired footing resistance cannot be achieved, supplemental grounding by use of driven grounds or counterpoise may be considered.

The lightning impulse insulation strength is a required input in both the IEEE and the CIGRE methods. For air, porcelain, or fiberglass, the CFO gradient for a positive polarity lightning impulse is approximately 560 kV/m. For insulation that consists of wood and porcelain in series, the CFO is a function of the critical length of wood, which is approximately equal to twice the insulator string length. At this critical length, the CFO is equal to the CFO of wet wood alone, about 300 kV/m. At about half the critical length, wood adds only about 40 kV/m to the insulator CFO.

The footing resistance R_i at high impulse current may be estimated by Equation (31):

$$R_i = \frac{R_0}{\sqrt{1 + \frac{I_R}{I_g}}} \quad (31)$$

where

- R_0 is footing resistance measured with low current
 I_R is the lightning current through the footing resistance
 I_g is the current required to produce a soil gradient, E_0 , at which soil breakdown occurs

This current is given by Equation (32):

$$I_g = \frac{1}{2\pi} \frac{\rho E_0}{R_0^2} \quad (32)$$

where

- ρ is the soil resistivity in $\Omega\text{-m}$
 E_0 is the soil breakdown gradient, assumed as 400 kV/m

Counterpoise is often used in areas of high soil resistivity. Furthermore, since even counterpoise grounding may not be sufficient to achieve the desired BFR, the insulator string length used in these areas is frequently longer than in areas of low soil resistivity.

The BFR of present lines varies significantly with the system voltage; 345 kV and 500 kV lines generally have BFRs in the range of 0.3 to 0.6 flashovers per 100 km-year. The BFR for 138- and 230 kV may range from 0.6 to 2 whereas lower voltage lines may have BFRs of 4 to 15 flashovers per 100 km-year.

6.3.1.3 Improving performance of existing lines

Generally, the primary method of improving the flashover rate of an existing design is by use of supplemental grounding, which almost universally consists of counterpoise. However, in cases where counterpoise cannot be installed because of soil conditions (rock formations) or because towers are on public areas such as roads, improvements in performance may be achieved by doing the following:

- Increasing the number of insulators and strike distance,
- Using an under-built shield wire, or
- Using arresters.

Increasing the insulation strength of the line, although generally not possible without considerable alteration of the tower structure, may be achievable in specific cases. The use of an under-built shield wire, positioned below the phase conductor, increases the coupling factor to the phase conductors, thus improving the BFR.

Arresters may also be used to decrease the flashover rate on transmission and distribution lines. To date their application has been primarily for

- Specific line sections where counterpoise grounding is either unsuccessful in lowering the footing resistance or where counterpoise cannot be installed,
- One circuit of a double-circuit lines to decrease the double-circuit flashover rate, and
- River crossing towers. However, new line designs are being considered which employ arresters as an alternative to overhead ground wires.

6.3.1.4 Example—shielding failure

As an example, assume a 500 kV line having a horizontal configuration of phase conductors located at a height of 22 m. The overhead ground wires are to be located at a height of 30 m. The design value of the SFFOR is 0.05 flashovers per 100 km-year. For purposes of this example, also assume a phase conductor height of 37 m with a shield wire height of 45 m. The strike distance is 3.30 m. Using a negative polarity CFO gradient of 605 kV/m gives a CFO of 1997 kV. The shielding angle values for different tower heights are calculated using both IEEE and CIGRE methods. The results of the computer analyses are shown in Table 15. The IEEE and CIGRE methods appear to agree for the lower tower heights but differ by over 2:1 for larger heights. As expected, the required shielding angle decreases as the ground flash density increases.

Table 15—Required shielding angle for a SFFOR of 0.05/100 km-yr

Ground flash density, flashes/km ² -yr	Ground wire height, m	Phase conductor height, m	Shielding angle IEEE degrees	Shielding angle CIGRE degrees
0.5	30	22	38	42
	45	37	12	28
3.0	30	22	335	36
	45	37		19
5.0	30	33	32	35
	45	37	4	17

6.3.1.5 Example—backflash

The 115 kV line insulation has a positive polarity CFO of 1120 kV. The single circuit line has horizontally located phase conductors with a conductor height of 14 m and a span length of 230 m. The ground flash density is 6 flashes per square km per year. Two shield wires are at a height of 17.4 m.

The BFR can be estimated by the IEEE or CIGRE method. Using the CIGRE method, the BFR as a function of the measured footing resistance is shown in Figure 5

Three curves are drawn for alternate ratios of the soil resistivity, (ρ) to the measured footing resistance (R_o .) The soil resistivity plays an important part in determining the BFR. A typical ρ/R_o ratio of 20 can be used if the soil resistivity is unknown.

The IEEE method is more conservative since it assumes $R_o = R_i$. When the soil resistivity is known the CIGRE method may be used.

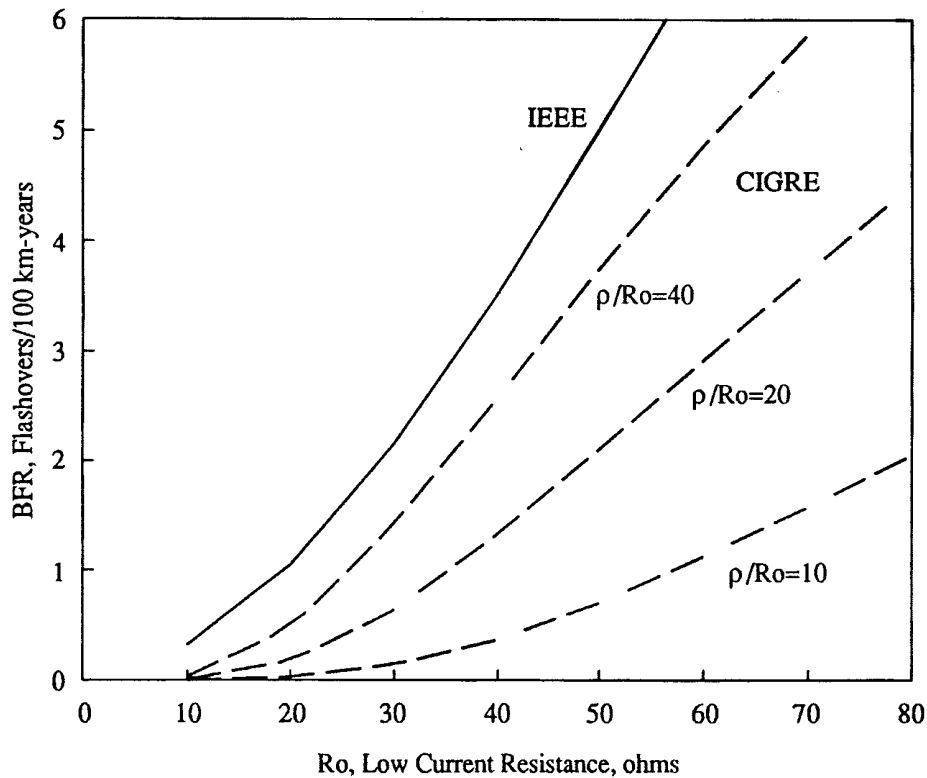

Figure 5—BFR as obtained from IEEE and CIGRE methods

6.3.2 Substations

The insulation coordination process is usually only performed for stations at a new system voltage or for a new station configuration at an existing system voltage. It consists of selecting the location of shielding masts or shield wires, the BILs, the clearances, surge arresters (the rating, number, and location), and the analysis of the opened circuit breaker voltage. Because of experience gained from similar stations, the process may be shortened or circumvented when additional stations are considered. At lower system voltages, the BILs and clearances have been selected and the task is to provide adequate arrester protection.

6.3.2.1 Shielding

The shielding process of the substation is similar to that of a transmission line. Shield wires and masts are used to effectively enclose and protect equipment. The design of substation shielding is described in IEEE Std 998-1996.

6.3.2.2 Open breaker position

When the breaker is opened for a prolonged period, the breaker disconnect switches are usually open. This prevents the impingement of surges on the breaker, and any flashover would normally occur to ground at the disconnect switch. Departures from this practice are rare, but if an open breaker with a closed disconnect normally exists, some form of protection should be used.

A breaker is also vulnerable to subsequent strokes of a lightning flash. When a lightning surge travels into the station with the breakers closed, the arrester(s) protect the breaker within the station. The breaker clears the line fault in about 40–100 ms and recloses in about 300–750 ms. However, a lightning flash is composed of one or more strokes and a subsequent stroke may occur while the breaker(s) is open and unprotected.

The following three solutions to this problem have been proposed:

- Apply arresters on the line side of all breakers
- Apply rod gaps on the line side
- Do nothing

All three methods have been used—and all have been “successful.” The first method works the best but is expensive. The second method is far less expensive but is also less effective. In addition, it is sometimes difficult to set the gap spacing. The gap spacing should be large enough so that the arrester can prevent flashover under normal conditions but small enough to protect the breaker when it is open. The last method is simply accepting the probabilities of a flashover. The calculation of the number of flashovers per year at the open breaker or the mean recurrence interval is as follows:

- a) From lightning flash data concerning the number of strokes per flash and the interstroke interval, the probability of a subsequent stroke occurring within the open breaker time range of 50–300 ms is about 0.46.
- b) The voltage must be sufficiently large to exceed the breaker withstand strength of 1.29 (CFO). The CFO used for this calculation is the 2 μ s withstand voltage of the breaker. The voltage doubles at the open circuit, therefore the voltage arriving at the breaker must be greater than 1/2 of the breaker withstand strength.
- c) The voltage at the struck point is the subsequent stroke current times the impedance at the struck point (approximately equal to the footing resistance).

Typical values of the mean recurrence interval for a single breaker are shown in Table 16. Thus, if there are one hundred 115 kV breakers in a system, the interval decreases to one in 47 years. The mean recurrence interval (or reliability) decreases with a decreased BIL and an increased BFR. Therefore, the open breaker problem increases rapidly as system voltage decreases.

Table 16—Opened breaker flashover mean recurrence interval

Nominal system voltage, kV	Circuit breaker BIL, kV	BFR, flashovers/100 km-yr	Mean recurrence interval/years
69	350	5.0	35
115	550	3.0	470
230	900	2.0	29 000
345	1300	1.0	3 000 000

6.3.2.3 Selection of the incoming surge

The incoming surge is the surge voltage that arrives at the station entrance and is caused by a backflash or shielding failure on the transmission line. It is selected based on the desired reliability of the station. This is normally specified in terms of the MTBF. Typical values range from about 50–200 years for air-insulated stations to 200–800 years for gas-insulated stations.

The magnitude and wave shape of the surge are functions of the distance to the location of the flashover, the type of lightning event (backflash or shielding failure), the conductor size, and the reliability desired as specified by the MTBF. Soil resistivity also affects the shape of the surge, when it is initiated distant from the station. However, since important surges are initiated within a few kilometers of the station, the effect of soil resistivity can be neglected.

The incoming surge may be determined for both the shielding failure and the backflash. However, since shielding failure rates are normally small in comparison to the backflash rates, usually only the backflash event needs to be considered. The distance to the point of flashover, d , may be determined by using Equation (33):

$$d = \frac{1}{(\text{MTBF})(\text{BFR})} \quad (33)$$

where

MTBF is in years
 d is in km if the BFR is in flashovers/100 km-years

Since flashovers are considered to occur only at tower locations, then d should be increased to an integer number of spans, or be increased to the distance to the next tower.

The steepness of the surge at the flashover point is decreased by corona. The approximation of the front steepness, S , at the line entrance, in kV/ μ s, is shown in Equation (34):

$$S = \frac{S_0}{1 + S_0 \frac{d}{K_S}} \quad (34)$$

where

S_0 is the steepness at the flashover location in kV/ μ s
 d is in km
 K_S is the corona constant in kV/s per km of travel

For a backflash, the steepness of the surge at the flashover location is essentially infinite, which reduces Equation (34) as shown in Equation (35):

$$S = \frac{K_S}{d} \quad (35)$$

Table 17 presents the suggested value of K_S .

Table 17—Suggested value of the corona constant

Conductor	K_S , (kV-km)/ μ s
Single conductor	700
Two conductor bundle	1000
3 or 4 conductor bundle	1700
6 or 8 conductor bundle	2500

The tail of the incoming surge for the backflash may be evaluated by the time constant, τ in microseconds as shown in Equation (36):

$$\tau = \frac{Z_g T_s}{R_i} \quad (36)$$

where

- Z_g is the surge impedance of the overhead ground wires
- R_f is the footing resistance at high impulse current
- T_S is the travel time for one span, in microseconds

In general, the impulse resistance is approximately 1/2 of the footing resistance measured with the typical low current test method. The time constant of the tail of the incoming surge for a backflash is small, in the order of 10–30 μ s. In contrast, the time constant of the tail of the incoming surge for a shielding failure is equal to the time constant of the tail of the stroke current, which averages 133 μ s.

The crest magnitude of the incoming surge can be calculated for a specific value of MTBF. For the backflash, the crest voltage typically varies from 0.85 to 1.2 times the lightning impulse positive polarity CFO of the line. A conservative value is 1.2 times the CFO.

For the shielding failure, the crest value is typically 30% to 50% of the lightning impulse negative polarity CFO of the line. Consequently, the shielding failure need not be considered.

The distance to the point of flashover in Equation (34) is applicable to all station equipment for a single-line station. For an n-line station, “n” lines gather “n” times as many strokes as a single-line station and transmit them to the transformer bus. Therefore, the distance to the flashover point must be divided by “n” for the transformer and equipment on the transformer bus. To maintain the same MTBF, Equation (34) *for a transformer* becomes Equation (37):

$$d = \frac{1}{n(\text{MTBF})(\text{BFR})} \quad (37)$$

The steepness of the incoming surge is “n” times the steepness for a single-line station. For example, for a transformer bus in a three-line station a 300-year surge should be used to obtain a MTBF of 100 years. However, for the incoming line equipment not on the transformer bus, Equation (33) is applicable and the 100-year surge should be used for a station MTBF of 100 years.

6.3.2.4 Contingency conditions

In normal station conditions, one assumes that all lines are in service. If contingency conditions, e.g., lines out of service, are important, then the probabilities of the contingency should be evaluated to arrive at an appropriate incoming surge value.

6.3.2.5 Selection of arrester rating and preliminary location of arresters

The selection of the arrester MCOV rating and class is described in IEEE Std C62.22-1991.

Lightning protection studies have to be performed with the arresters located in accordance with utility practices. In the absence of a standard practice, the arresters are located adjacent to the transformer.

6.3.2.6 Digital transient program model

Generally, only a single-phase model of the station is required. Station buses are modeled as distributed parameter lines described by their surge impedances and length. Transformers are modeled by their surge capacitances, which vary between 1 nF–6 nF, with 2 nF being an average value. Circuit breakers are modeled by a surge impedance and distance through the breaker. The capacitance of oil bushings is between 300 pF and 600 pF. The circuit for applying the incoming surge varies, depending on the distance to the flashover point.

If this distance is long, the circuit is a voltage source and a resistance connected in series. The source voltage is the time function of the incoming surge with double amplitude. The resistance is the line surge impedance. The distance is considered long if twice the travel time between the stroke terminating point and the equipment is longer than the time-to-crest value of the voltage at the equipment. From a practical viewpoint, a distance of a few kilometers is assumed to be long. Figure 6 shows the equivalent circuit, where Z is the line surge impedance, and E is the amplitude of the incoming wave.

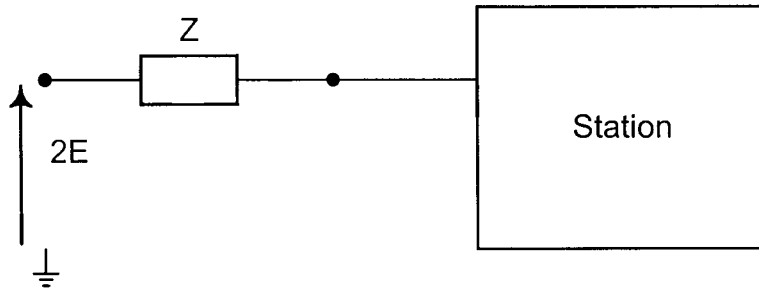

Figure 6—Equivalent circuit for long distances to the flashover point

If the distance to the flashover point is short, reflection between the flashover point and the station entrance tends to increase the voltage within the station. Therefore, the circuit as shown in Figure 7 should be used. This circuit consists of a voltage applied through an impedance, roughly equal to the tower footing resistance, and a distributed parameter line section. The length of the line is equal to the distance to the flashover location. The surge impedance and the traveling time represent the line. The distance is considered short if twice the travel time between the stroke terminating point and the equipment is shorter than the time-to-crest value of the voltage at the equipment. From a practical point of view, a distance less than 1 km is assumed to be short.

In Figure 7, the parameters are define as follows:

- d is the distance between flashover point and station
- R is the tower footing resistance
- Z is the line surge impedance
- E is the incoming wave

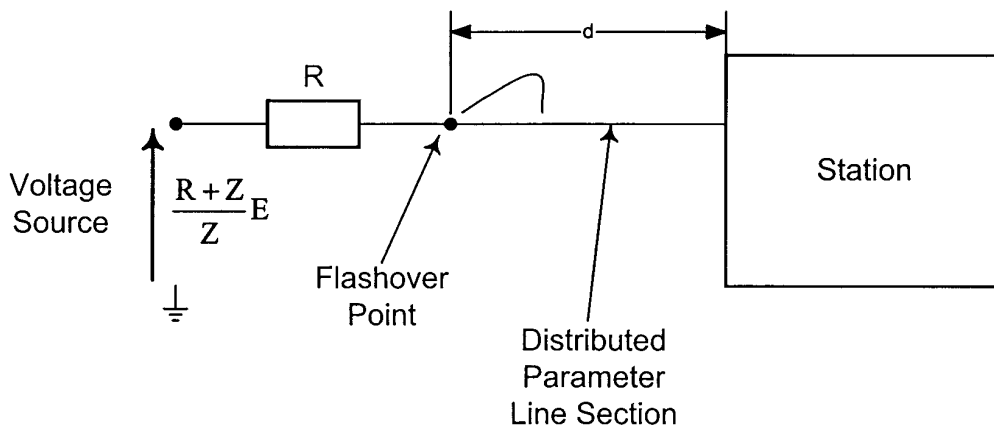

Figure 7—Equivalent circuit for short distances to the flashover point

6.3.2.7 Selection of BILs and clearances

Surge voltage wave shapes measured at equipment locations and at open points throughout the stations do not normally resemble the standard lightning impulse wave shape, on which the BILs or insulation strength is based. Therefore, a method is required to change the crest surge voltage to an equivalent crest voltage for a 1.2/50 μ s impulse.

For self-restoring insulation, several methods are used for conversion of the actual voltages to an equivalent 1.2/50 μ s impulse. A simplified method is presented here.





For non-self-restoring insulation, e.g., the transformer, only a simplified evaluation is presently possible.

Because the strength of non-self-restoring insulation is specified by a conventional BIL, a minimum protective margin of 15% is generally recommended. However, industry typically uses higher margins.

For self-restoring insulation, the use of protective margins is not generally recommended. The recommended method is to place the margin on the MTBF by increasing its value. The higher MTBF results in an increase in the severity of the incoming surge.

Clearances are estimated using the highest equivalent crest voltage for the 1.2/50 μ s wave shape and dividing it by a negative polarity critical breakdown gradient. This critical gradient is a function of the gap configuration and varies from about 540 kV/m to about 660 kV/m. The typical value is 605 kV/m. Table 18 shows the CFO values for alternate gap configurations with gap spaced 4 m. For gaps with insulators, all flashover occurs across the insulator. In this case, the insulators determine the insulation strength. For elevations higher than sea level, the insulation strength decreases as a linear function of the relative air density. The sea level BILs and clearances must be divided by the relative air density.

Table 18—Lightning impulse CFOs for gaps with and without insulators

Values are for 4 m gap		Positive polarity CFO kV/m		Negative polarity CFO kV/m	
Gap configurations	Diagram	Without insulator	With insulator	Without insulator	With insulator
Rod-plane		540	520 540	660	375 500
Conductor outside arm		600 625	500 520	600 625	595 620
Conductor upper structure		575	560	625	610
Conductor upper rod		655	500	595	585
Rod-rod		560	500	640	425 475

The CFO vs. distance curve is non-linear, values are for 4 m.

If the required BILs and clearances are considered excessive, additional arresters may be employed within the station, or the severity of the incoming surge may be decreased while maintaining the MTBF by improving the lightning performance of the towers or lines adjacent to the station. This is accomplished practically by decreasing the footing resistance, increasing the insulator string length, and/or applying surge arresters.

For stations whose lines are unshielded, overhead shield wires can be added for some distance from the station. The length of the shielded section should be greater than or equal to the calculated distance to the flashover, d . See Equation (33) and Equation (37)].

6.3.3 Simplified method

The simplified method is suitable for obtaining an approximation of protection requirements or BILs for relatively small or simple stations. It can also be used to obtain initial estimates for more complex stations before initiating a detailed study. Figure 8 shows a typical arrangement. This method may also be used to obtain initial estimates of protection requirements and BILs for more complex stations before initiating a full study.

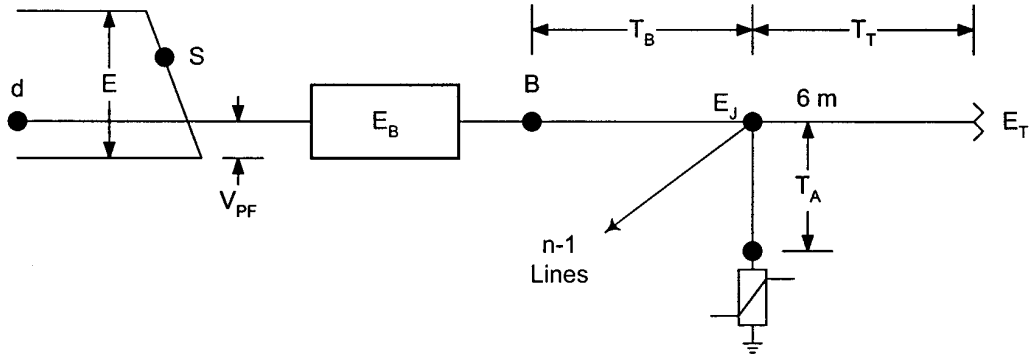

(a) With transformer

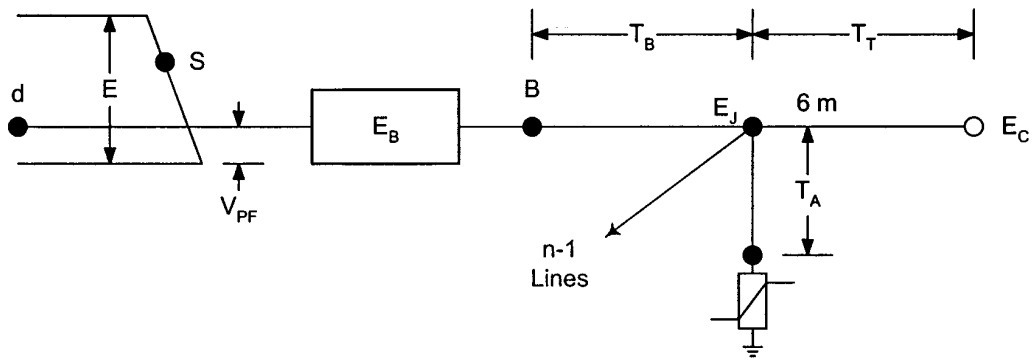

(b) Without transformer

Figure 8—Circuits for simplified model

6.3.3.1 Incoming surge

Calculate the distance to the flashover point, d , by using Equation (38).

$$d = \frac{1}{n(\text{MTBF})(\text{BFR})} \tag{38}$$

For the calculation of the voltages at the transformer and at the equipment on the transformer bus use n , which is equal to the total number of lines terminating at the station, including the line receiving the surge. For other equipment use $n = 1$, regardless of the number of lines. Extend the value of d to the next, more distant, tower, and with this new value of d , estimate the front steepness, S , using Equation (39):

$$S = \frac{K_s}{d} \quad (39)$$

where

K_s is corona constant, obtained from Table 17

6.3.3.2 Voltage at equipment

a) Definitions:

- E is the crest voltage of the incoming surge, conservatively assumed as 1.2 times the positive polarity lightning impulse CFO of the line insulation
- S is the steepness of the front of the incoming surge [calculated by Equation (35) or Equation (39)]
- E_T is the surge voltage at transformer
- E_t is the total voltage-to-ground at transformer
- E_d is the arrester discharge voltage
- E_A is the arrester discharge voltage plus the power frequency voltage
- E_J is the surge voltage at arrester bus junction
- E_j is the total voltage-to-ground at arrester bus junction
- E_B is the surge voltage at the breaker
- E_b is the total voltage-to-ground at the breaker
- E_C is the surge voltage at an open end
- E_c is the total voltage-to-ground at an open end
- T_C is the travel time between arrester-bus junction and open line end
- T_A is the travel time between arrester and arrester-bus junction
- T_B is the travel time between arrester-bus junction and circuit breaker
- T_T is the travel time between arrester-bus junction and transformer
- V_{PF} is the power frequency voltage of opposite polarity to the surge, equal to 83% of the crest line-to-neutral power frequency voltage. This is a conservative average value, which results in equal surge voltages across all phase insulation. Less conservative values are 72% for horizontal phase, 40% for vertical phase configuration.
- R_A is the apparent resistance of arrester, resistance between any two points on the voltage-current characteristic around the estimated discharge current value
 $RA = (E_{A2} - E_{A1}) / (I_{A2} - I_{A1})$
- n is the total number of lines, including the line receiving the surge
- E_o is the starting voltage for linear piece-wise model of arrester voltage-current characteristic

The arrester discharge voltage is shown in Figure 9 and may be defined as shown in Equation (40):

$$E_d = E_0 + I_A R_A \tag{40}$$

or may be more simply selected as equal to the 0.5 μs discharge voltage.

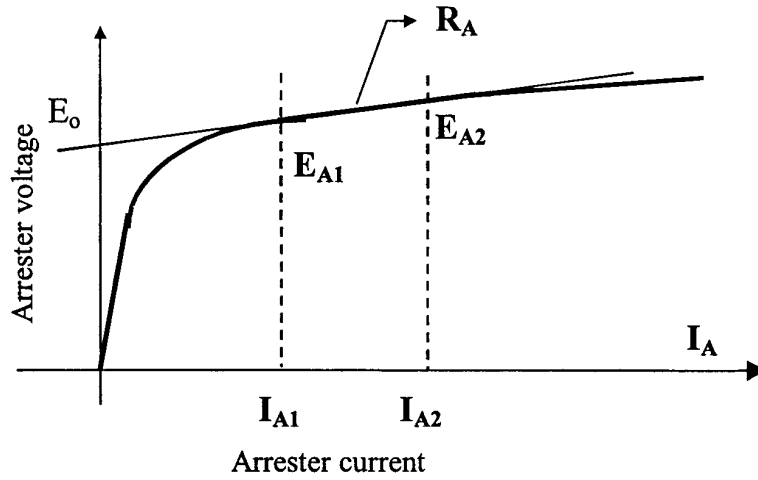

Figure 9—Arrester characteristics

The relationship between the voltages defined previously is shown in Equation (41):

$$\begin{aligned} E_A &= E_d + V_{PF} \\ E_J &= E_j + V_{PF} \\ E_T &= E_t + V_{PF} \\ E_B &= E_b + V_{PF} \\ E_C &= E_c + V_{PF} \end{aligned} \tag{41}$$

The voltages at the transformer are illustrated in Figure 10.

- b) Voltage at the transformer [(Figure 8, part a)]:

The transformer is modeled by its capacitor to ground. The arrester discharge current, I_A , is shown in Equation (42):

$$I_A = 1.6 \frac{\frac{2E}{n} - E_A}{\frac{Z}{n}} = 1.6 \frac{\frac{2E}{n} - E_0 - V_{PF}}{\frac{Z}{n} + R_A} \tag{42}$$

where

Z is the surge impedance of the bus

n is the number of lines

The voltage at the transformer is shown in Equation (43a):

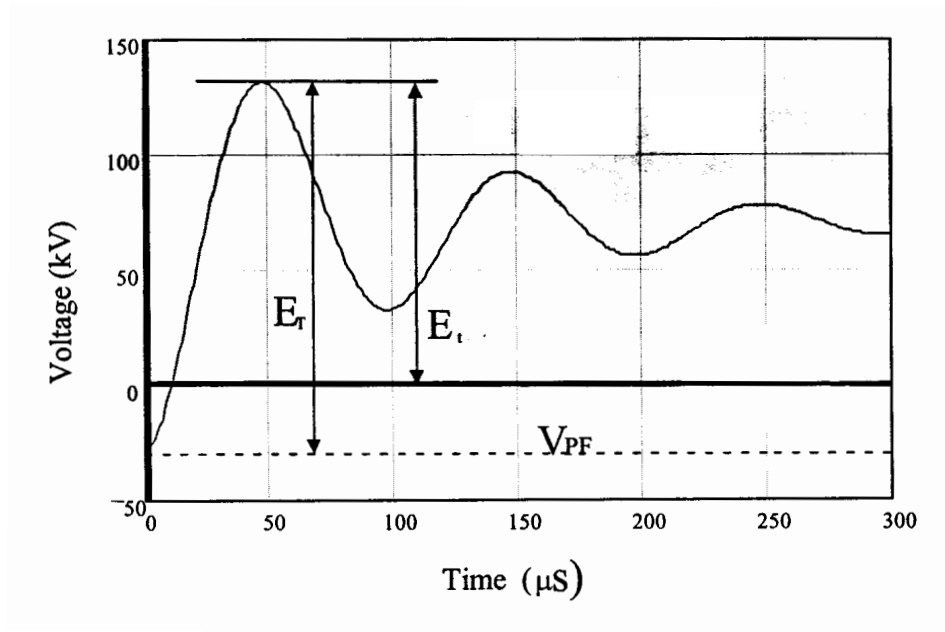

Figure 10—Transformer voltage

$$\frac{E_T}{E_A} = 1 + \frac{A}{1 + \frac{B}{K_1}} \quad (43a)$$

where

$$K_1 = \frac{S(T_T + T_A)}{E_A} \quad (43b)$$

Table 19 gives the value of constants A and B, as the function of the number of lines.

Table 19—Constants A and B

Number of lines	A	B
1	1	0.14
2	0.98	0.16
3	0.84	0.18
4	0.68	0.25

- c) Voltage at an open end in point C (Figure 8b, transformer required)

The arrester current at the open end in point C without transformer is shown in Equation (44):

$$I_A = \frac{\frac{2E}{n} - E_A}{\frac{Z}{n}} \quad (44)$$

The voltage at the open end in point C without transformer is shown in Equation (45):

$$E_C = E_A + \frac{2S}{n} T_C \quad \text{for} \quad \frac{ST_C}{E_A} = 0 \quad \text{to} \quad \frac{n}{6} \quad (45)$$

$$E_C = \frac{4}{n+3} (E_A + 2ST_C) \quad \text{for} \quad \frac{ST_C}{E_A} = \frac{n}{6} \quad \text{to} \quad \frac{n+1}{4}$$

The calculated voltage using this equation is less than 10% higher than the voltages calculated by digital programs.

- d) Voltage at point B with transformer [see Figure 8, part a)]:

The voltage at the breaker or at any point behind the arrester is conservatively given by Equation (46a), parts a–c.

$$E_B = E_J + 2ST_B \quad (46a)$$

where the voltage E_J is found from:

$$\frac{E_J}{E_A} = 1 + \frac{A}{1 + \frac{B}{K_2}} \quad (46b)$$

Where A and B are obtained from Table 19 and K_2 is:

$$K_2 = \frac{ST_A}{E_A} \quad (46c)$$

The maximum value of E_B is E.

- e) Voltage at point B without transformer (Figure 8b) [See Equation (47)]:

$$E_B = E_A + 2S(T_B + T_A) \quad (47)$$

6.3.3.3 Estimating the BIL and clearance

- a) *Transformer*: The transformer BIL is estimated assuming a safety margin of 15% and using the crest value E_t and the time-to-crest value t_T .

If the time-to-crest value, t_T , is more than 3 μ s, then the transformer BIL is as shown in Equation (48):

$$\text{BIL} = 1.15E_t \quad (48)$$

If the time to crest, t_T , is equal to or less than 3.0 μ s, and $E_t/E_d \leq 1.10$, then [see Equation (49)]:

$$\text{BIL} = 1.15 \frac{E_t}{1.10} \quad (49)$$

In addition to the above criteria, for an incoming surge whose tail time constant is greater than 30 μ s, Equation (50) applies:

$$\text{BSL} = \frac{1.15}{0.83} E_d \quad (50)$$

The reason for this criterion is that the longer tailed incoming surges produce arrester discharge voltages whose tail exceeds the tail of the standard lightning impulse. Therefore, the discharge voltage is compared to the BSL, which is established by an impulse with a much longer tail. This criterion applies principally to incoming surges caused by shielding failures but should be checked for incoming surges caused by backflashes (see 6.3.2).

An approximation for the time to crest of the transformer voltage is shown in Equation (51):

$$t_T = \pi \sqrt{(T_T + T_A)(ZC_T + T_T)} + \frac{E_A}{S} \quad (51)$$

- b) *Other equipment*: For the other equipment, the calculated voltage may be directly compared to the chopped wave level of the equipment. If standard tests do not require a chopped wave test, a chopped wave voltage capability of 1.15 times the BIL may be assumed. Therefore if δ is the relative air density, then [see Equation (52)]:

$$\text{if } \frac{E_b}{E_d} \leq 1.15 \text{ then } \text{BIL} = \frac{E_d}{\delta} \text{ or if } \frac{E_b}{E_d} \geq 1.15 \text{ then } \text{BIL} = \frac{E_d}{1.15\delta} \quad (52)$$

- c) *Clearance*. The required clearance may be estimated by dividing the maximum voltage in the station by the selected gradient. A suggested gradient is 605 kV/m for a negative polarity surge. The clearances required by NESC and other standards should be compared with the calculated values.

The calculated clearance applies for both phase-phase and phase-ground. This conservatively assumes that the flashover occurs on only one phase and the stroke termination point is near the station.

6.3.4 Application examples

The application of the simplified method consists of comparing the insulation stress to the strength. The calculations will be compared with results using a digital transient program and transformer capacitances of 2 nF and 4 nF.

6.3.4.1 Single-line station

Figure 11 shows a single-line diagram for a 230 kV station.

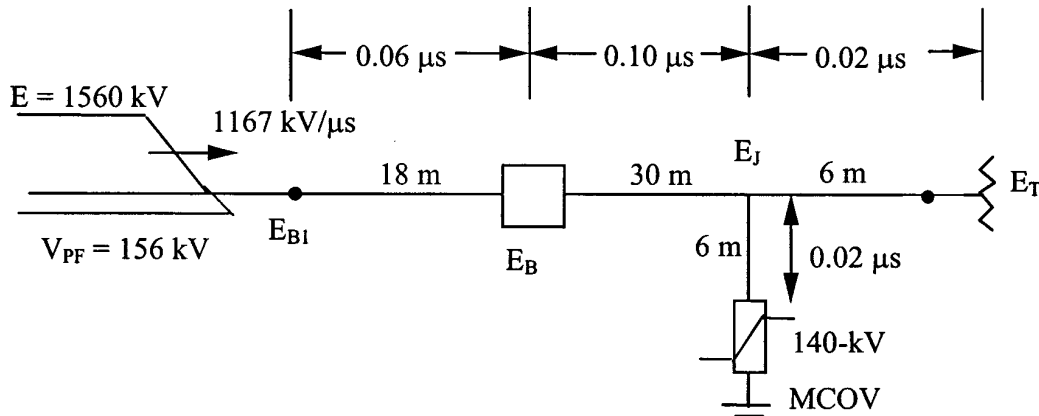

Figure 11—Single-line diagram of a 230 kV station

- a) *The incoming surge:* The 230 kV single line station ($n = 1$) of Figure 10 is to be designed for an MTBF of 100 years. The BFR of the line is 2.0 flashovers/100 km-years and the span length is 300 m. The distance to flashover d is calculated from Equation (38) as shown in Equation (53):

$$d_m = \frac{1}{n(\text{MTBF})(\text{BFR})} = \frac{1}{(100)(2/100)} = 0.5 \text{ km} \quad (53)$$

Since the span length is 300 m, this distance is increased to 600 m (the next tower location) and using a corona constant, K_S , of 700, the steepness of the incoming surge is calculated by Equation (39), as shown in Equation (54):

$$S = \frac{K_S}{d} = \frac{700}{0.6} = 1167 \frac{\text{kV}}{\mu\text{s}} \quad (54)$$

The CFO of the line insulation is 1300 kV and a very conservative estimate of the crest voltage of the incoming surge is 1.2 times the CFO of the line, or $E = 1.2 (1300) = 1560$ kV. This surge is superimposed on an opposite polarity power frequency voltage, V_{PF} . The value of V_{PF} is equal to the 83% crest line to neutral voltage, as shown in Equation (55):

$$V_{PF} = 230 \frac{\sqrt{2}}{\sqrt{3}} 0.83 = 155.8 \text{ kV} \quad (55)$$

- b) *Arrester current and voltage:* The 140 kV MCOV arrester selected has a 0.5 μs discharge voltage of 464 kV at 10 kA. The 8/20 μs discharge voltage at 10 kA is 421 kV and at 5 kA is 404 kV. The division of 464 kV by 421 kV shows that the 0.5 μs discharge voltage is about 10% higher than 8/20 μs discharge voltages. The 0.5 μs discharge voltage is $(1.10)(404) = 444$ kV. Typical

arrester characteristics are shown in Figure 8. Using this figure the arrester resistance, R_A is calculated by Equation (56):

$$R_A = \frac{E_{A2} - E_{A1}}{I_{A2} - I_{A1}} = \frac{(464 - 444)}{(10 - 5)} = 4 \Omega \quad (56)$$

The arrester resistance is:

E_0 is calculated with Equation (40). Its value is:

$$E_0 = E_d - I_A R_A = 444 - 5 \cdot 4 = 424 \cdot \text{kV} \quad \text{OR} \quad 464 - 10 \cdot 4 = 424 \cdot \text{kV}$$

The line surge impedance is: $Z = 450 \Omega$.

Using these values, the arrester current is calculated by Equation (42), as shown in Equation (57):

$$I_A = 1.6 \frac{\frac{2E}{n} - E_0 - V_{PF}}{\frac{Z}{n} + R_A} = 1.6 \frac{2(1560) - 424 - 156}{450 + 4} = 8.95 \text{ kA} \quad (57)$$

The arrester discharge voltage, using Equation (40), is shown in Equation (58):

$$E_d = E_0 + I_A R_A = 424 + (8.95)(4) = 460 \text{ kV} \quad (58)$$

Therefore, the arrester discharge voltage plus the power frequency voltage is as seen in Equation (59):

$$E_A = E_d + V_{PF} = 460 + 156 = 616 \text{ kV} \quad (59)$$

- c) *Transformer:* At the transformer terminal, E_T is determined by Equation (43a) and Equation (43b). From Figure 11, the travel times are: $T_A = 0.02 \mu\text{s}$, $T_B = 0.1 \mu\text{s}$, $T_T = 0.02 \mu\text{s}$. First K_1 is calculated using Equation (43b), as shown in Equation (60):

$$K_1 = \frac{S(T_T + T_A)}{E_A} = \frac{1167 \cdot 0.04}{616} = 0.07578 \quad (60)$$

The A and B constants are determined from Table 19. The values for one line are $A = 1$ and $B = 0.14$. From Equation (43a) we get [see Equation (61)]:

$$\frac{E_T}{E_A} = 1 + \frac{A}{1 + \frac{B}{K_1}} = 1 + \frac{1}{1 + \frac{0.14}{0.07578}} = 1.351 \quad (61)$$

The surge voltage at the transformer terminal is shown in Equation (62):

$$E_T = (1.351)(616) = 832 \text{ kV} \quad (62)$$

The voltage to ground at the transformer terminal is shown in Equation (63):

$$E_t = E_T - V_{PF} = 832 - 156 = 676 \text{ kV} \quad (63)$$

The time-to-crest values at the transformer is calculated by Equation (51).

If the transformer capacitance is $C_T = 2$ nF, the time-to-crest value is as shown in Equation (64):

$$t_T = \pi\sqrt{(T_T + T_A)(ZC_T + T_T)} + \frac{E_A}{2S} = \pi\sqrt{0.04(450 \times 2 \cdot 10^{-3} + 0.02)} + \frac{616}{1167} = 1.13 \mu\text{s} \quad (64)$$

If the transformer capacitance is $C_T = 4$ nF, the time-to-crest value is as shown in Equation (65):

$$t_T = \pi\sqrt{(T_T + T_A)(ZC_T + T_T)} + \frac{E_A}{S} = \pi\sqrt{0.04(450 \times 4 \cdot 10^{-3} + 0.02)} + \frac{616}{1167} = 1.38 \mu\text{s} \quad (65)$$

- d) *Arrester-bus junction*: The surge voltage and the voltage to ground at the arrester-bus junction are determined by Equation (46b) and Equation (46c). First K_2 is calculated using Equation (46c), as shown in Equation (66):

$$K_2 = \frac{ST_A}{E_A} = \frac{(1167)(0.02)}{616} = 0.03789 \quad (66)$$

The A and B constants are the same as before $A = 1$ and $B = 0.14$. From Equation (46b) we get [see Equation (67)]:

$$\frac{E_J}{E_A} = 1 + \frac{A}{1 + \frac{B}{K_1}} = 1 + \frac{1}{\frac{1 + 0.14}{0.03789}} = 1.213 \quad (67)$$

The total junction voltage is shown in Equation (68):

$$E_J = (1.213)(616) = 747 \text{ kV} \quad (68)$$

The voltage to ground is calculated by subtracting the V_{PF} from the total junction voltage, as seen in Equation (69):

$$E_j = E_J - V_{PF} = 747 - 156 = 591 \text{ kV} \quad (69)$$

- e) *Circuit breaker*: From Figure 11 the travel times are: $T_B = 0.1 \mu\text{s}$ [see Equation (70)]:

$$\begin{aligned} E_B &= E_J + 2ST_B = 747 + 2(1167)(0.10) = 980 \cdot \text{kV} \\ E_b &= E_B - V_{PF} = 980 - 156 = 824 \cdot \text{kV} \end{aligned} \quad (70)$$

- f) *Station entrance*: From Figure 11 the travel times are: $T_C = 0.06 \mu\text{s}$, $T_B = 0.1 \mu\text{s}$ [see Equation (71)]:

$$\begin{aligned} E_{B1} &= E_J + 2S(T_C + T_B) = 747 + 2(1167)(0.16) = 1120 \cdot \text{kV} \\ E_{b1} &= E_{B1} - V_{PF} = 1120 - 156 = 964 \cdot \text{kV} \end{aligned} \quad (71)$$

To determine the accuracy of these simplified calculations, a digital transient program was used with the assumption that the tail-time constant of the incoming surge is $14 \mu\text{s}$. The calculation may be performed using different tail-time constant values. The results are presented in Figure 12, which shows the voltage vs. time functions. Table 20 compares the peak values of the voltages, obtained from Figure 12 with the voltages calculated by the simplified method presented here. Except for the voltage at the transformer, all voltages calculated using the simplified equations are higher than the voltages found by the digital simulation, i.e., from 0% to 4.3%. The calculated transformer voltages

are 3.6% lower than those determined by the digital simulation, assuming a 4 nF transformer capacitance.

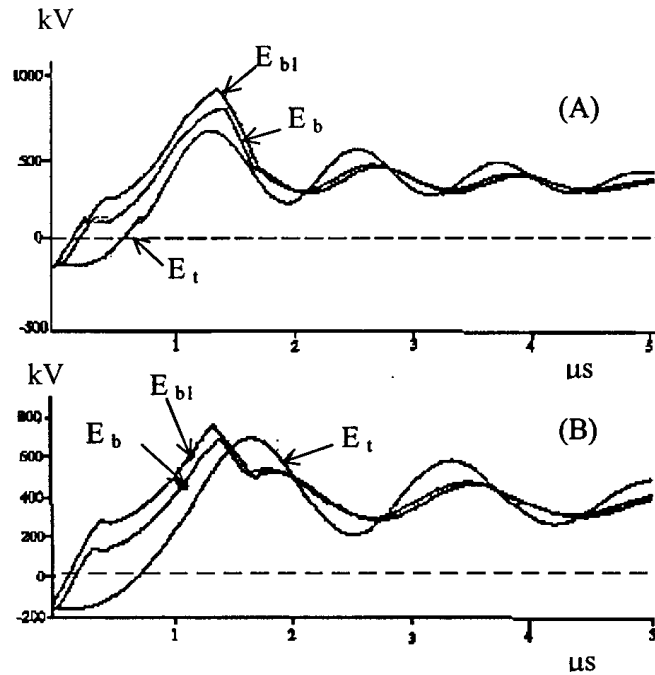

Figure 12—Voltages for single line station (a) $C_T = 2$ nF, (b) $C_T = 4$ nF

Table 20—Comparison of results for single line station

Voltage	Simplified calculation	Digital transient program	
		$C_T = 2$ nF	$C_T = 4$ nF
E_t	676	679	700
E_b	824	815	695
E_{b1}	964	929	766
E_j	591	582	571
E_d	460	455	460
I_A	8.9	7.6	8.9

The selected BILs are shown in Table 21. The BILs produced by calculation are listed under “Req’d BIL.” These are usually non-standard values. The next highest standard BILs are selected from 4.6 of IEEE Std 1313.1-1996 and listed under “Std BIL” in Table 21. The final “Selected BILs” are taken from relevant apparatus standards.

The process to determine the BIL is detailed below.

- g) *Transformer BIL:* From Equation (49), the BIL is calculated as shown in Equation (72):

$$\text{BIL} = 1.15 \frac{E_t}{1.10} = 1.15 \frac{676}{1.10} = 707 \text{ kV} \quad (72)$$

From 4.6 of IEEE Std 1313.1-1996, the next highest standard BIL is 750 kV. From the applicable transformer standard, the transformer BIL of 750 kV is selected.

- h) *Transformer bushing*: Both the internal and external insulation must be considered in evaluating the transformer bushing. The internal bushing is treated in an identical manner as the transformer. The single-line station is at sea level. The required BIL for the external porcelain, using Equation (52) is shown in Equation (73):

$$BIL = \frac{E_t}{1.15} = \frac{676}{1.15} = 588 \text{ kV} \tag{73}$$

Table 21—Selection of BILs for single-line station

Equipment	Voltage	Crest, kV	Req'd BIL, kV	Std BIL, kV	Selected BIL, kV
Transformer	E_t	676	707	750	750
Transformer bushing:					
Internal	E_t	676	707	750	750
External		676	588	650	750
Breaker	E_b	824	717	750	900
Disc switch	E_b	824	717	750	900
Bus insulators	All	964	838	900	900

The next standard BIL from 4.6 of IEEE Std 1313.1-1996 is 650 kV. From the applicable apparatus standard, the minimum available BIL is 650 kV. However, to permit the impulse test of the transformer the BIL of the external insulation should be equal to or greater than the internal BIL. Therefore, the selected BIL for the external and internal insulation is 750 kV.

If the station is located at a higher elevation, the BIL of the external porcelain should have a higher BIL than the internal insulation. For example, if the station is at an elevation of $A = 1600 \text{ m} = 1.6 \text{ km}$, the relative air density, using Equation (15) is shown in Equation (74):

$$\delta = e^{\frac{A}{8.6}} = e^{\frac{-1.6}{8.6}} = 0.830 \tag{74}$$

The CFO at higher elevation is calculated using Equation (14). The m value for lightning impulse is $m = 1$. The CFO decreases, consequently the required BIL increases with the increase of elevation. The required BIL is seen in Equation (75):

$$BIL_{\delta} = \frac{BIL}{\delta} = \frac{588}{0.830} = 708 \text{ kV} \tag{75}$$

Therefore, the selected BIL remains 750 kV.

- i) *Circuit breaker*: The required BIL, using Equation (52), is seen in Equation (76):

$$BIL = \frac{E_b}{1.15} = \frac{824}{1.15} = 717 \text{ kV} \tag{76}$$

The next standard BIL is 750 kV. The applicable circuit breaker standard gives a BIL of 900 kV. If the station were at 1600 m, the required BIL would be 863 kV and the breaker standard BIL of 900 kV would still be applicable.

- j) *Disconnecting switches:* In this sample problem, the disconnecting switches are assumed to be located at the breaker, and therefore, the BILs are the same as for the breaker.
- k) *Bus support insulators:* The bus support insulators are located throughout the station, and therefore, the surge voltage selected is the maximum found throughout the station, a value of 964 kV. The required BIL is shown in Equation (77):

$$\text{BIL} = \frac{E_{B1}}{1.15} = \frac{964}{1.15} = 838 \text{ kV} \quad (77)$$

From 4.6 of IEEE Std 1313.1-1996, the next highest BIL is 900 kV; this becomes the selected BIL.

- l) *Air clearances:* The highest calculated voltage in the station is 964 kV, and therefore, the required clearance (phase-ground and phase-phase) is calculated by using a gradient of 605 kV/m for a negative polarity surge, as seen in Equation (78):

$$\text{Clearance} = \frac{964}{605} = 1.6 \text{ m} \quad (78)$$

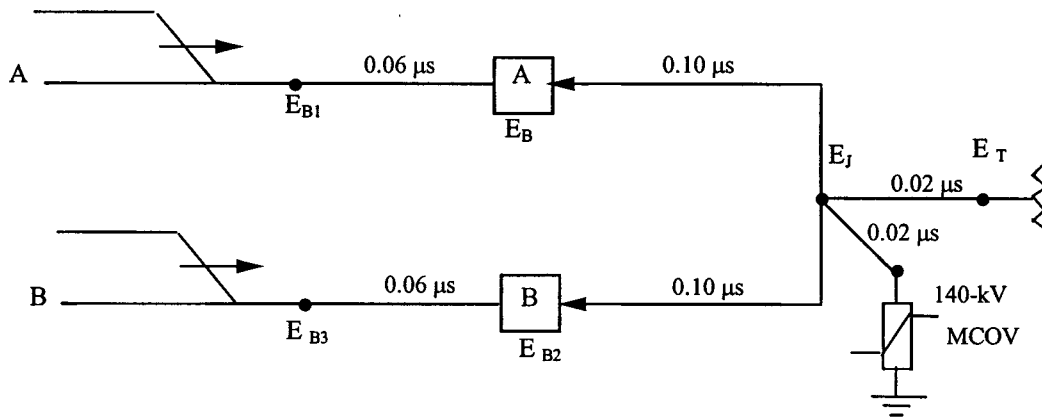

Figure 13—Single-line diagram of a 230 kV, two-line station

6.3.4.2 Two-line station

Figure 13 shows a 230 kV station single-line diagram. This station is identical to that of Figure 11 except an additional line has been added.

- a) *Transformer and adjacent equipment with both lines in service:*

Incoming surge: with $n = 2$ [see Equation (79)]:

$$d_m = \frac{1}{n(\text{MTBF})(\text{BFR})} = \frac{1}{2(2/100)(100)} = 0.25 \text{ km} \quad (79)$$

This distance is increased to one span length so that $d_m = 0.3 \text{ km}$. Thus [see Equation (80)]:

$$S = \frac{K_S}{d} = \frac{700}{0.3} = 2333 \frac{\text{kV}}{\mu\text{s}} \quad (80)$$

As before, the crest of the incoming surge is conservatively assumed as 1560 kV.

Arrester current and voltage: Using the arrester characteristics as before [see Equation (81)]:

$$I_A = 1.6 \frac{\frac{2E}{n} - E_0 - V_{PF}}{\frac{Z}{n} + R_A} = 1.6 \frac{1560 - 424 - 156}{225 + 4} = 6.85 \text{ kA} \quad (81)$$

Since the current is between 5 kA and 10 kA, the calculation for $R_A = 4 \Omega$ is acceptable. The arrester voltages are seen in Equation (82):

$$\begin{aligned} E_d &= E_0 + I_A R_A = 424 + (4)(6.85) = 451 \cdot \text{kV} \\ E_A &= E_d + V_{PF} = 451 + 156 = 607 \cdot \text{kV} \end{aligned} \quad (82)$$

Transformer: The $A = 0.98$ and $B = 0.16$ values are obtained from Table 19. The surge voltages and time-to-crest values at the transformer, if the transformer capacitance is $C_T = 2 \text{ nF}$ or 4 nF , is shown in Equation (83):

$$\begin{aligned} t_T &= \pi \sqrt{(T_T + T_T)(ZC_T + T_T)} + \frac{E_A}{S} = \pi \sqrt{0.04(450 \cdot 2 \cdot 10^{-3} + 0.02)} + \frac{607}{2333} = 0.863 \mu\text{s} \\ t_T &= \pi \sqrt{(T_T + T_T)(ZC_T + T_T)} + \frac{E_A}{S} = \pi \sqrt{0.04(450 \cdot 4 \cdot 10^{-3} + 0.02)} + \frac{607}{2333} = 1.11 \mu\text{s} \\ K_1 &= \frac{S(T_T + T_A)}{E_A} = \frac{(2333)(0.04)}{607} = 0.1537 \\ \frac{E_T}{E_A} &= 1 + \frac{A}{1 + \frac{B}{K_1}} = 1 + \frac{0.98}{1 + \frac{0.16}{0.1537}} = 1.4802 \end{aligned} \quad (83)$$

Arrester-bus junction for the transformer evaluation:

$$\begin{aligned} K_2 &= \frac{S T_A}{E_A} = \frac{(2333)(0.02)}{607} = 0.0769 \\ \frac{E_J}{E_A} &= 1 + \frac{A}{1 + \frac{B}{K_1}} = 1 + \frac{0.98}{1 + \frac{0.16}{0.0769}} = 1.318 \\ E_J &= 1.318 \cdot 607 = 800 \text{ kV} \quad E_j = E_J - V_{PF} = 800 - 156 = 644 \text{ kV} \end{aligned} \quad (84)$$

b) *For other equipment not on transformer bus:*

Incoming surge with $n = 1$: These equipment BILs are evaluated using a 100-year surge and thus, the steepness, S , remains at 1167 kV/ μ s, and the crest voltage is 1560 kV.

Arrester-bus junction for other equipment [see Equation (85)]:

$$K_2 = \frac{S T_A}{E_A} = \frac{(1167)(0.02)}{607} = 0.0385$$

$$\frac{E_J}{E_A} = 1 + \frac{A}{1 + \frac{B}{K_1}} = 1 + \frac{0.98}{1 + \frac{0.16}{0.0385}} = 1.1899 \quad (85)$$

$$E_J = 1.1899 \cdot 607 = 722 \text{ kV} \quad E_j = E_J - V_{PF} = 722 - 156 = 566 \text{ kV}$$

Circuit breaker [see Equation (86)]:

$$E_B = E_J + 2ST_B = 722 + 2(1167)(0.10) = 955 \text{ kV}$$

$$E_b = E_B - V_{PF} = 955 - 156 = 799 \text{ kV} \quad (86)$$

Station entrance [see Equation (87)]:

$$E_{B1} = E_J + 2S(T_C + T_B) = 722 + 2(1167)(0.16) = 1095 \text{ kV}$$

$$E_{b1} = E_{B1} - V_{PF} = 1095 - 156 = 939 \text{ kV} \quad (87)$$

Voltages E_{B2} and E_{B3} : The circuit breaker voltage, E_{B2} , and station entrance voltage, E_{B3} , are equal to voltage at the arrester-bus junction E_j since line B does not have any discontinuities.

Comparison with digital transient program: The voltages calculated by the simplified method and those obtained by use of the digital transient program (ATP) are compared in Table 22. Most calculated voltages are within 0–18% greater than those obtained using digital simulation.

Table 22—Comparison of results for two-line station, surge on line A

Voltage	Simplified calculation	ATP	
		$C_T = 2 \text{ nF}$	$C_T = 4 \text{ nF}$
200-year surge			
E_t	742	728	668
E_j	644	577	547
E_d	451	451	452
I_A	6.9	6.8	6.9
100-year surge			
E_b	799	754	629
E_{b1}	939	844	684
E_j	566	543	532
E_{b2}	566	543	532
E_{b3}	566	543	532

Selection of BILs: The selection of the BIL as detailed in Table 23 employs the same methodology as for the single-line and therefore is not repeated here. Note that in comparison to the single line, the BIL of the transformer has been increased. However, the required and standard BIL of the other equipment has decreased. Since the standard breaker BIL is 900 kV BIL, this value is selected. Similarly, the standard BIL for the bus support insulators is 900 kV, so the selected BIL does not change.

Table 23—Selection of BILs for two-line station

Equipment	Voltage	Crest, kV	Req'd BIL, kV	Std BIL, kV	Selected BIL, kV
Transformer	E_t	742	776	825	825
Transformer bushing					
Internal	E_t	742	776	825	825
External		742	646	650	825
Breaker	E_b	799	695	750	900
Disc switch	E_b	799	695	750	900
Bus insulators	All	939	816	825	900

Plots of the voltages as obtained from the digital simulation are presented in Figure 14.

Clearances: The phase-ground and the phase-phase clearance required is $939/605 = 1.55$ m.

Reevaluation of use of MTBS of 100 years: The BILs of equipment not on the transformer bus was determined using a 100-year surge. For this case, the voltage at the disconnecting switch, E_b , was 799 kV. If the surge were placed on line B, the voltage would have been 566 kV.

Thus, voltages of 799 kV and 566 kV appear once in 100 years, and the voltage of 799 kV is used to determine the BIL.

In a similar manner, the voltages, E_{b1} , at the station entrance are 939 kV and 566 kV with the BIL based on 939 kV. Thus, the use of the 100-year surge is justified.

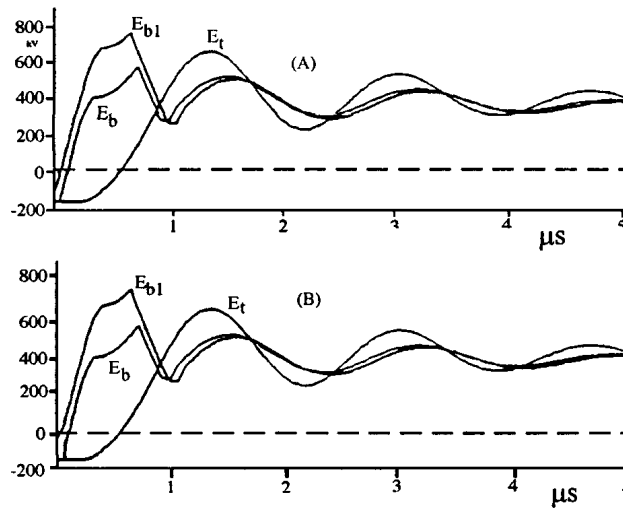

Figure 14—Voltages in two-line station (a) $C_T = 2$ nF, (b) $C_T = 4$ nF

6.3.4.3 Contingency conditions

Figure 15 illustrates the one-line open contingency (the disconnects on each side of breaker B are opened). Assume that the probability of all lines in service, during a thunderstorm, is 75% and therefore the probability of only one line in service is 25%. Thus, to maintain the 100-year MTBF, the return period of the surge should be 100 times 0.25 or 25 years. However, with equal probability, line A or line B could be out of service. Thus, the surge could arrive on line A or on line B. Therefore, the transformer BIL should be evaluated

on an MTBS of 50 years. A 50-year surge has a d of 1.2 km and therefore a steepness of 583 kV/ μ s. A 25-year surge has a d of 2.1 km and therefore a steepness of 333 kV/ μ s. Since this is now a single-line station, assuming the crest of the incoming surge remains at 1560 kV, the voltages are the same as for the single-line case, i.e., $E_d = 460$ kV and $E_A = 616$ kV.

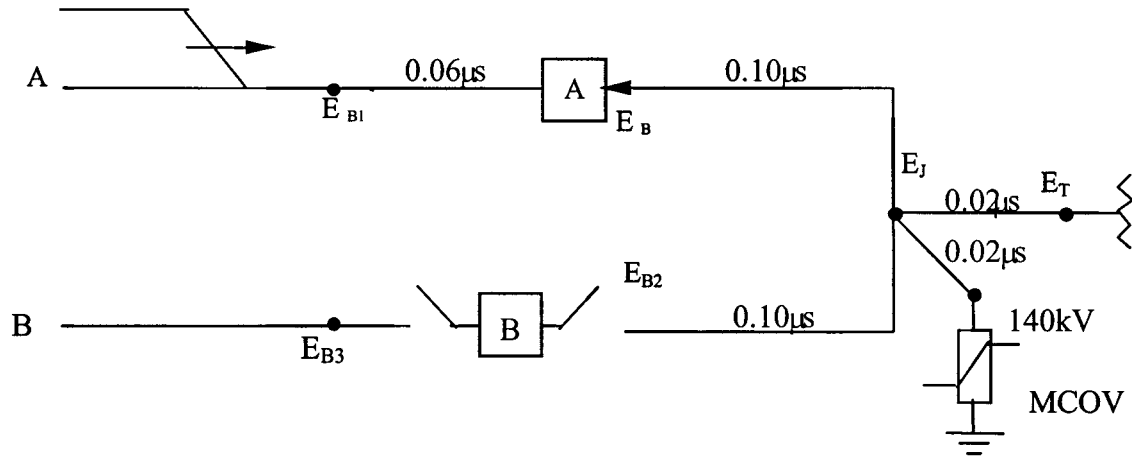

Figure 15—One line out in a two-line station

The surge having a steepness of 583 kV produces a transformer voltage, E_t , of 591 kV, which is significantly less than the voltage of 742 kV for all lines in service. See Equation (88).

$$K_1 = \frac{S(T_T + T_A)}{E_A} = \frac{(583)(0.04)}{616} = 0.03786$$

$$\frac{E_J}{E_A} = 1 + \frac{A}{1 + \frac{B}{K_1}} = 1 + \frac{1}{1 + \frac{0.14}{0.03786}} = 1.213 \quad (88)$$

$$E_J = (1.213)(616) = 747.2 \text{ kV}$$

$$E_j = E_J - V_{PF} = 747.2 - 156 = 591.2 \text{ kV}$$

To evaluate the other equipment BILs, first apply a 25-year surge to line A. The voltage at arrester-bus junction (point J) is shown in Equation (89):

$$K_2 = \frac{S T_A}{E_A} = \frac{(333)(0.02)}{616} = 0.0108$$

$$\frac{E_J}{E_A} = 1 + \frac{A}{1 + \frac{B}{K_2}} = 1 + \frac{1}{1 + \frac{0.14}{0.0108}} = 1.0717 \quad (89)$$

$$E_J = (1.0717)(616) = 660 \text{ kV}$$

$$E_j = E_J - V_{PF} = 660 - 156 = 504 \text{ kV}$$

Then the voltage at the breaker E_B is shown in Equation (90):

$$E_B = E_J + 2ST_B = 660 + 2(333)(0.10) = 727 \cdot \text{kV}$$

$$E_b = E_B - V_{PF} = 727 - 156 = 571 \cdot \text{kV} \quad (90)$$

The voltage at the station entrance E_{B2} is shown in Equation (91):

$$E_{B2} = E_A + 2S(T_C + T_B) = 616 + 2(333)(0.12) = 696 \cdot \text{kV}$$

$$E_{b2} = E_{B2} - V_{PF} = 696 - 156 = 540 \cdot \text{kV} \quad (91)$$

With the disconnect switch A open, the surge is now applied to line B. In this case, the voltage E_b is 540 kV and the voltage E_{B2} is 696 kV. Thus, once in 25 years, the two voltages, 571 kV and 540 kV, appear at the disconnecting switches. Therefore, the BIL should be based on a voltage of 571 kV. The required BIL is 497 kV; the next higher standard BIL is 550 kV. Thus, the required standard BIL is much less than for two lines in service. For the case of all lines in service, the calculated voltage E_{b2} for a surge on line B, is 939 kV, about 64% greater than for this contingency case.

The conclusion of this example is that the case of all lines in service is the most critical case and dictates the required BILs. This may not always be true. It depends on the assumed probability of the contingency, which in turn produces the steepness of the incoming surge.

If the voltage at breaker A, with B open, and the voltage at B, with A open, are equal, the calculation should be repeated with an MTBS of 50 years. For example, assume that these voltages are both equal to 700 kV. Thus two surges of 700 kV occur once in 25 years—or one voltage of 700 kV occurs once in 12.5 years. Therefore, the incoming surge should be based on a MTBS of 50 years and the calculations repeated.

Table 24—Air clearances IEC 60071-2 (1996)

BIL, kV	Clearance, mm		BIL, kV	Clearance, mm	
	Rod-structure	Conductor-structure		Rod-structure	Conductor-structure
20	60		950	1900	1700
40	60		1050	2100	1900
60	90		1175	2350	2200
75	120		1300	2600	2400
95	160		1425	2850	2600
125	220		1550	3100	2900
145	270		1675	3350	3100
170	320		1800	3600	3300
250	480		1950	3900	3600
325	630		2100	4200	3900
450	900				
550	1100				
650	1300				
750	1500				
850	1700	1600			

6.3.5 Clearances for lightning stroke

Clearances as a function of BIL are suggested in the IEC 60071-2 (1996) [B3] and are presented in Table 24. Above 450 kV BIL, they are based on a BIL withstand gradient of 500 kV/m. Below 450 kV BIL, the with-

stand gradient reduces steadily to 333 kV/m at 20 kV BIL. Note that some of these BILs differ from standard values given in the different IEEE apparatus standards.

For phase-ground, the minimum clearance for conductor-structure and rod-structure is applicable.

The clearances (strike distance) BILs in this guide are established on technical requirements. Before specification of these values, appropriate safety standards of the region or nation should be consulted. For example, in IEEE these are embodied in IEEE Std C2-1997 and IEEE Std 156-1995.

7. Final selection

The following summarizes the design requirements.

7.1 Transmission lines

The results from each area of investigation are as follows:

- a) Contamination:
 - 1) Insulator configuration
 - 2) Insulator type
 - 3) Number of insulators
 - 4) Insulator string length
- b) Switching surges:
 - 1) Insulator string length
 - 2) Phase-ground clearance (strike distance)
 - 3) Phase-phase clearance (strike distance)
- c) Lightning:
 - 1) Insulator string length
 - 2) Phase-ground clearance (strike distance)
 - 3) Location and number of overhead ground wires
 - 4) Need for and type of supplemental grounding
 - 5) Need for rating, number, and location of arresters

Each of the studies of switching surges, lightning, and contamination provide a specification of the insulator string length, and both switching surges and lightning provide specifications of the clearances (strike distance). In addition, in some cases, the strike distance and insulator lengths are not independent. The final design specification is the maximum of these quantities.

For economic reasons, the objective of the design is to select the minimum insulation strength. Thus, for example, if switching surges dictate the clearances (strike distance), ameliorating measures such as closing resistors in the breakers should be considered. If lightning dictates the design, further reduction in footing resistance may be desirable. If contamination dictates the design, perhaps alternate insulator types or RTV coating, etc., could be considered.

7.2 Substations

The results from each of the areas of investigation are:

- a) Contamination:
 - 1) Insulator type
 - 2) Length

- 3) Leakage distance
- b) Switching surges:
 - 1) Phase-ground and phase-phase BSLs
 - 2) Phase-ground and phase-phase clearances
 - 3) Arrester rating, class, and energy discharge capability
- c) Lightning:
 - 1) Location and type of station shielding
 - 2) BILs
 - 3) Phase-ground and phase-phase clearances
 - 4) Rating, number, and location of surge arresters
 - 5) Need for (and type) improvements in performance of towers adjacent to the station; for example, grounding, shielding, and addition of under-build conductors
 - 6) Need for and type of open breaker protection

For power apparatus, the relationships between the BIL and BSL are established by the appropriate standards. Therefore, the BIL and BSL can not be selected independently. The BIL and BSL obtained from the studies must be coordinated with the values specified in each apparatus standard.

The final specification of the clearances is the maximum value obtained from the switching surge and lightning studies.

As was the case for transmission lines, the overall objective is to specify the minimum insulation strength and not to permit one criterion to dictate the design. In the case of station design, if the lightning or switching surge criterion dominates the design, measures such as additional arresters may be considered.

Annex A

(informative)

Bibliography

[B1] IEC 60060-1 (1989), High-voltage test (techniques)—Part I: General definitions and test requirements.

[B2] IEC 60071-1 (1993), Insulation coordination—Part 1, Definition/principals and rules.

[B3] IEC 60071-2 (1996), Insulation coordination application guide.

[B4] IEC 60099-1 (1991), Surge arresters—Part 1, Non-linear resistor type gapped arresters for AC systems.

[B5] IEC 60099-4 (1991), Surge arresters—Part 4, Metal-oxide arresters without gaps for AC systems.

[B6] IEC 60282-1 (1994), High-voltage fuses—Part 1, Current limiting fuses, specifies maximum permitted over voltages generated by the operation of fuses unspecified test conditions.

[B7] IEC 60507 (1991), Artificial pollution test on high-voltage insulators.

[B8] IEC 60815 (1986), Guide for the selection of insulators in respect of polluted conditions.

[B9] IEEE Std 1243-1997, IEEE Guide for Improving the Lightning Performance of Transmission Lines.

[B10] CIGRE Technical Bulletin 63, Guide to procedures for estimating the lightning performance of transmission Lines. Oct. 1991.

[B11] Cortina, R., and Paris, L., “Switching and Lightning Impulse Discharge Characteristics of Large Air Gaps and Long Insulator Strings,” IEEE Transaction on PA & S, pp. 47–57, Apr. 1968.

[B12] Dillard, J. K., and Hileman, A. R., “UHV Transmission Tower Insulation Tests,” IEEE Transaction on PA & S, pp. 1772–1784, April 1965.

[B13] Guyker, W. C., Hileman, A. R., Wittibschlager, J. F., “Full Scale Tower Tests for APS 500 kV System,” IEEE Trans. on PA & S, June 1966, pp. 614–623.

[B14] Thione, L., “Evaluation of Switching Impulse Strength of External Insulation,” ELECTRA, pp. 77–95, May 1984.